

EWS-Varia V5

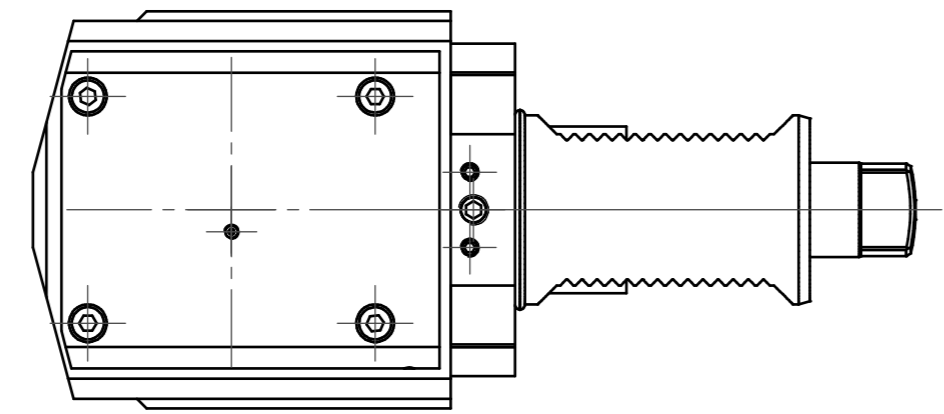

Doppelverzahnung Lizenz Traub  
double tooth system licence Traub

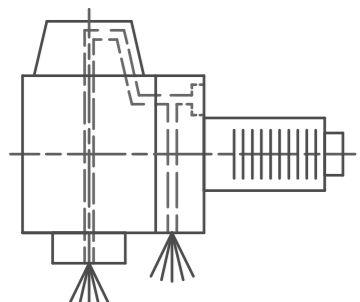
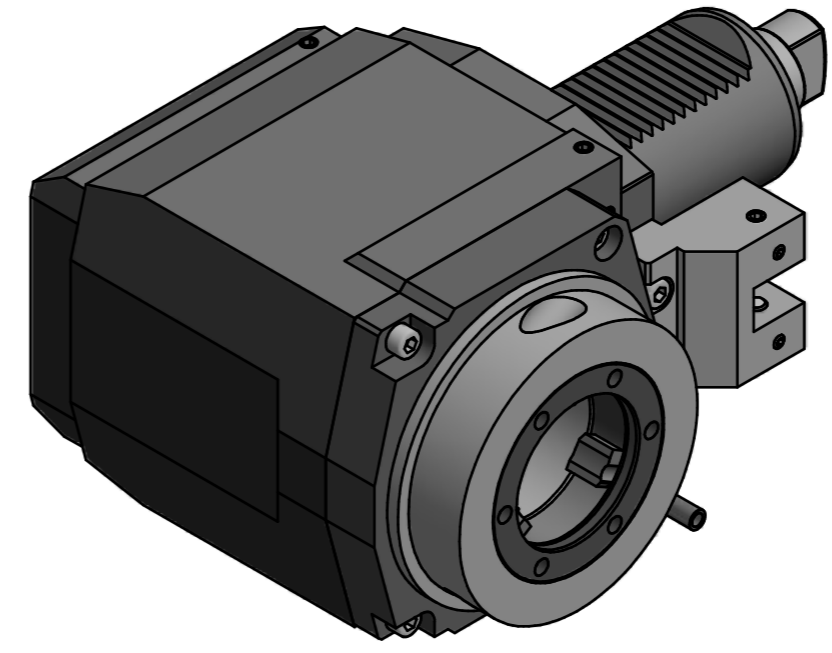

Innen- und Aussenkuehlung / Inside and outside coolant supply  
Kein Trockenlauf / No dry run  
Kuehlmittelfiltrierung-50µ / coolant filtration-50µ

Bemerkung - Note Nicht ohne Kuehlmittel betreiben! Not for use without coolant-fluid! mit Kegelrollenlager with taper roller bearing(s)	Technische Daten - technical data Weight = 11,121 [kg] Torque max. (M1/M2) = 80 / 160 [Nm] Speed max. (n1/n2) = 4000 / 2000 [1/min] Gear ratio (i)=n1:n2 = 2:1 Pressure (pmax) = 70 [bar]
---	--

Benennung - Title  
**Radial Bohr und Fräskopf**  
*Radial drilling and milling head*

<b>EWS</b> Tool Technologies <small>EWS Weigle GmbH &amp; Co. KG          Maybachstr. 1          D-73066 Uhringen          www.ews-tools.de</small>	Technische Aenderungen vorbehalten! Subject to technical modifications! IDENT: D-EWS-172006	MNR. REV: -/- 169992
	Nr. - No. <b>60.50V5KR1809HESSRLIKI2ASX75</b>	

Copyright **EWS Tool Technologies**  
 Weitergabe und Vervielfaeltigung dieser Unterlage,  
 Verwertung und Mitteilung ihres Inhalts nicht  
 gestattet, soweit nicht ausdrecklich zugestanden.  
 Zuwiderhandlungen verpflichten zu Schadenersatz.

