

**Sondermaschine!!!**  
Bitte eine Kollisionsprüfung durchführen.  
*Special machine design!!!*  
*Please make an interferences check.*

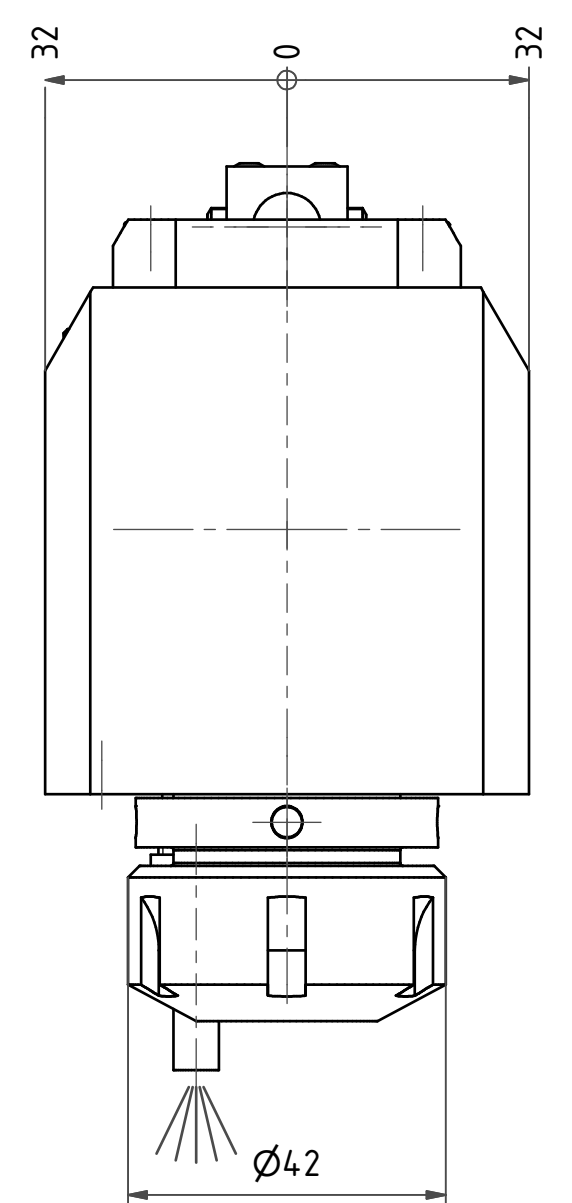

Spannzange / collet ER25 DIN6499  
 Spannbereich / clamping range: 1,0 - 16,0

Gewindebohrzange / tapping collet  
 ET-1-25 M3-M10

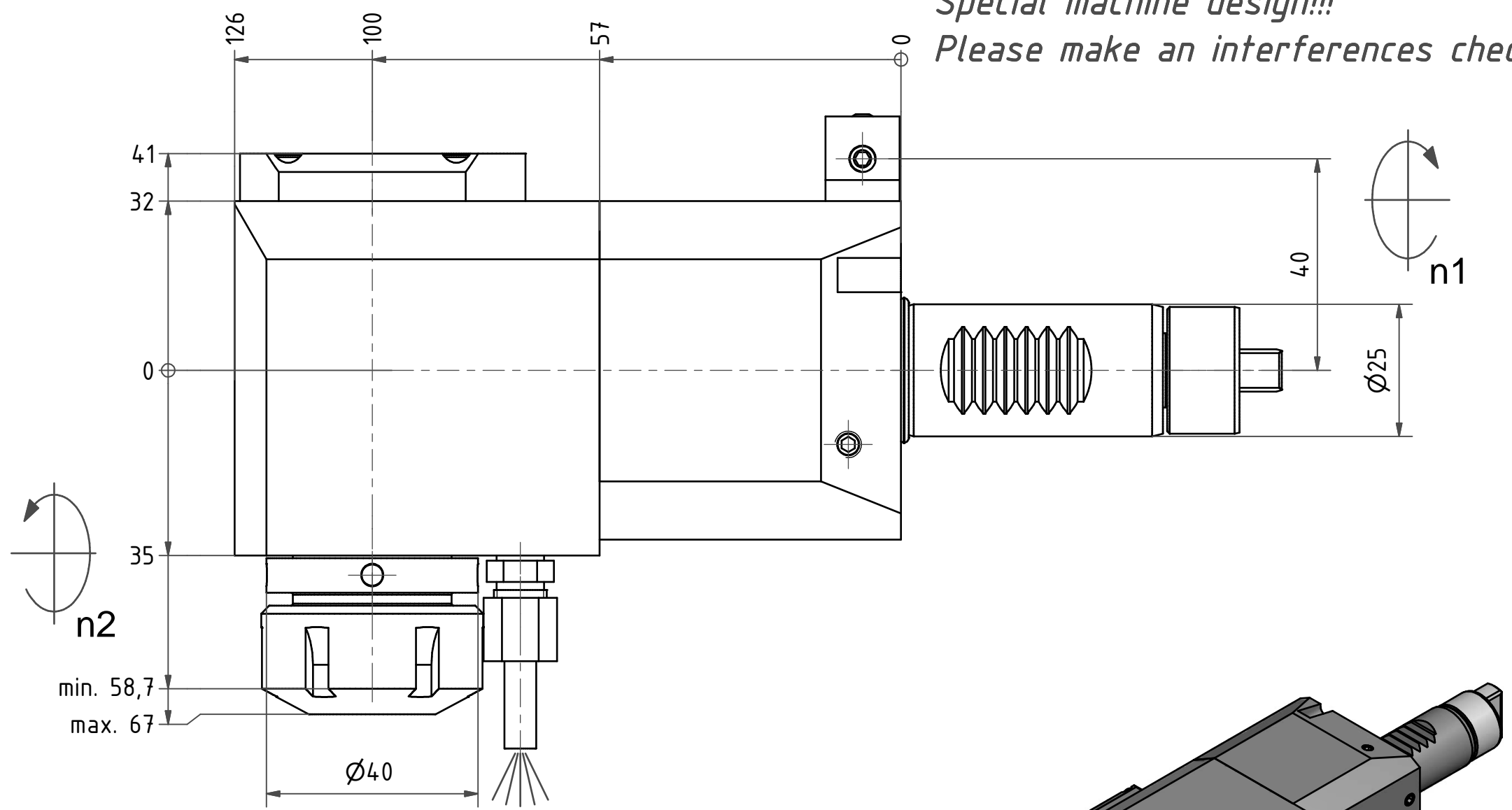
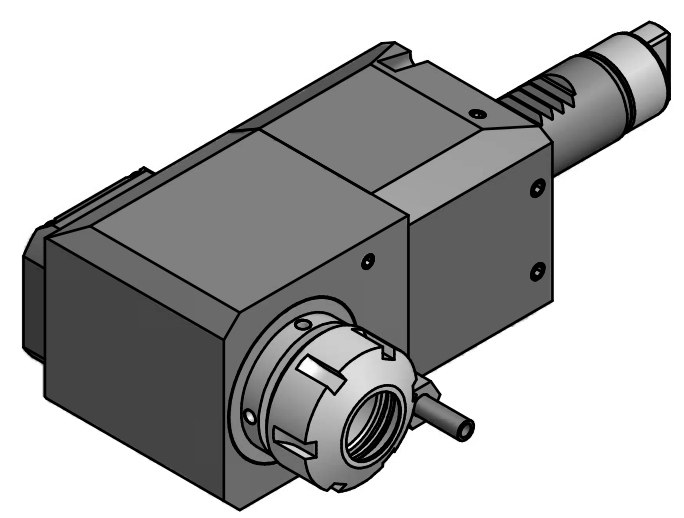

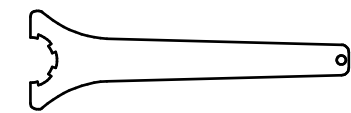
 Spannzangenschlüssel  
Clamping wrench  
225

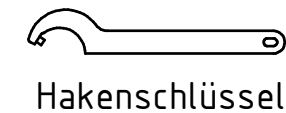
 Hakenschlüssel  
mit Zapfen  
Hook wrench  
with fixed pin  
DIN1810 B 40x42

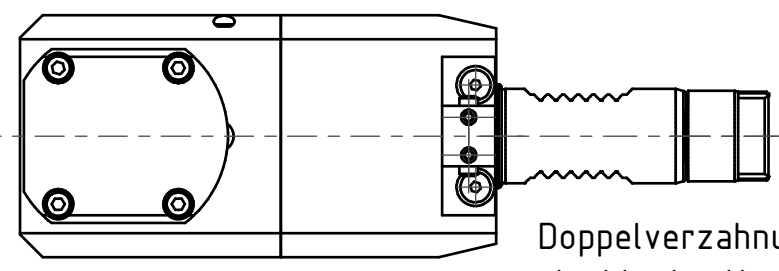

Doppelverzahnung Lizenz Traub  
*double tooth system licence Traub*

Copyright **EWS Tool Technologies**  
 Weitergabe und Vervielfaeltigung dieser Unterlage,  
 Verwertung und Mitteilung ihres Inhalts nicht  
 gestattet, soweit nicht ausdrecklich zugestanden.  
 Zuwiderhandlungen verpflichten zu Schadenersatz.

Bemerkung - Note	Technische Daten - technical data M1 / M2 = 25 / 25 Nm n1 / n2 = 8000 / 8000 1/min i (N1:N2) = 1:1	Benennung - Title <b>Radial Bohr und Fräskopf</b> <i>Radial drilling and milling head</i>	name	date	Technische Aenderungen vorbehalten! Subject to technical modifications!	 Nr. <b>60.2525TDRLX100</b> DIN A3	
			drawing	Theiss			27.06.2014
			 EWS Weigete GmbH & Co. KG Maybachstr. 1 D-73066 Uhingen Tel. +49(0)7161/93040-100		MNR: 164.794	IDENT: D-EWS-158613 -	Blatt - page 1 (1)