

Winkelausrichtung & CD-ROM  
in Lieferung enthalten!  
Angle-adjusting & CD-ROM  
included in delivery!

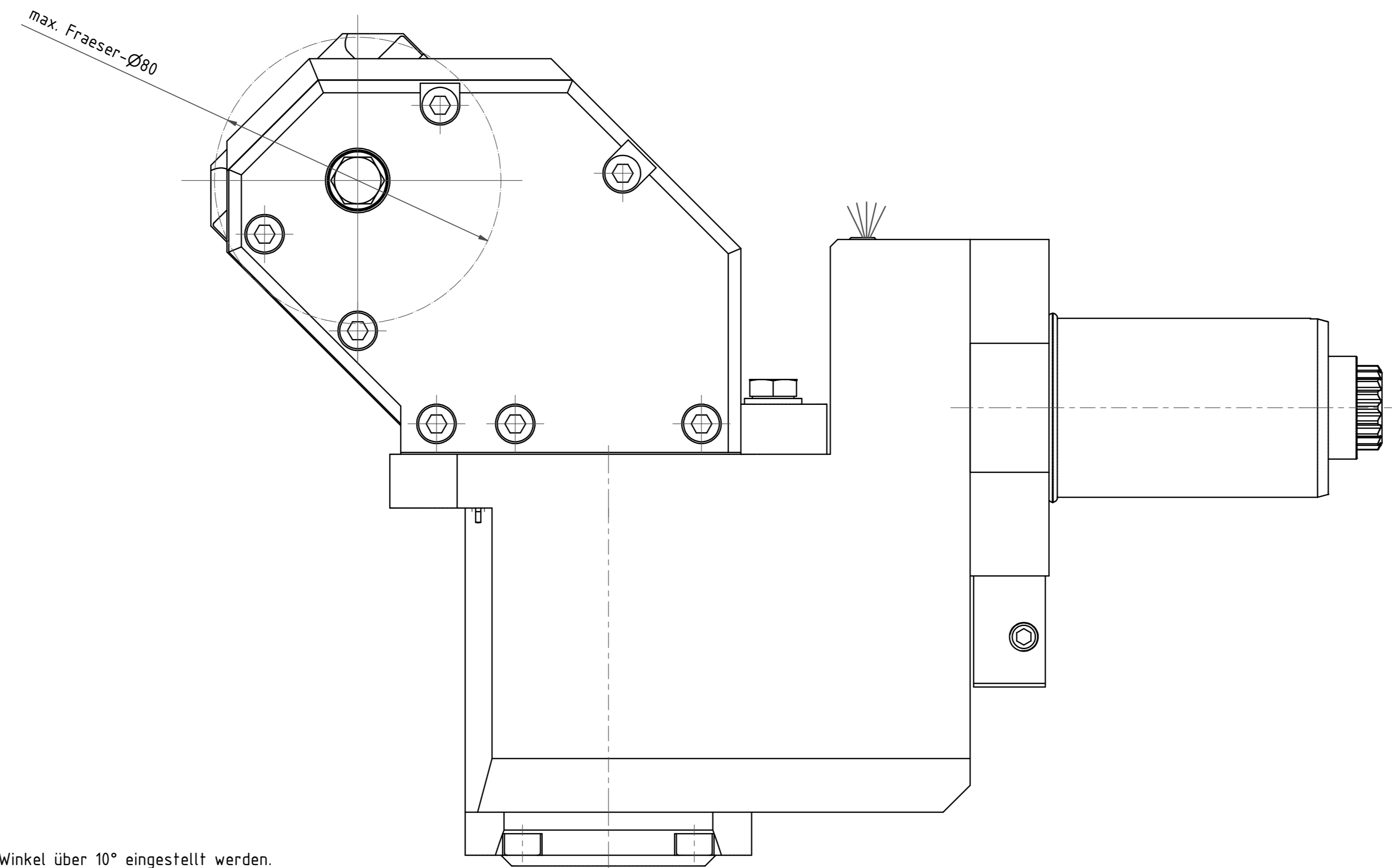

Auf Anfrage können auch Winkel über 10° eingestellt werden.  
Maschinenabhängig wegen Arbeitsraum.  
Angles over 10° can be preset on request.  
Machine-dependent due to workspace.

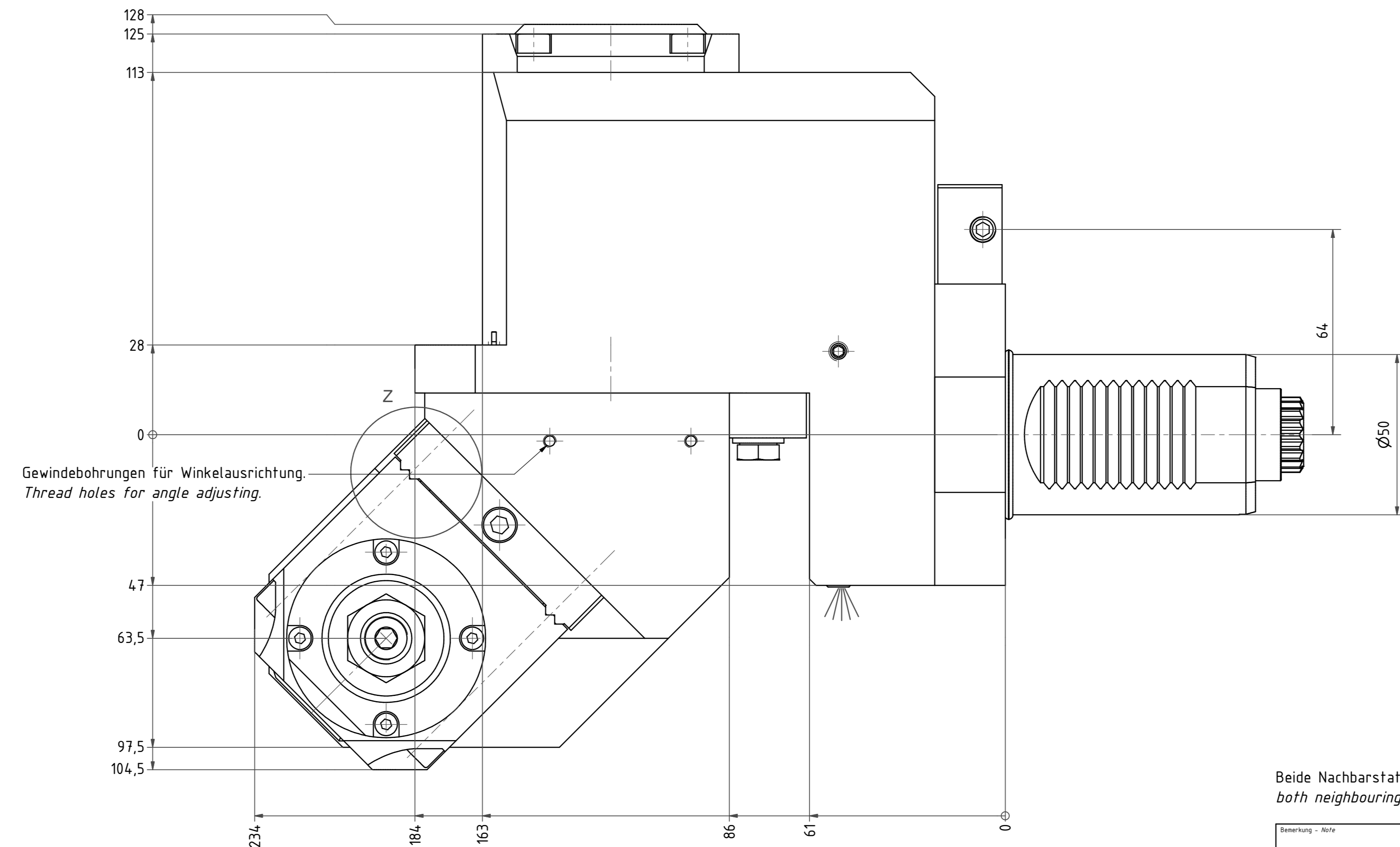
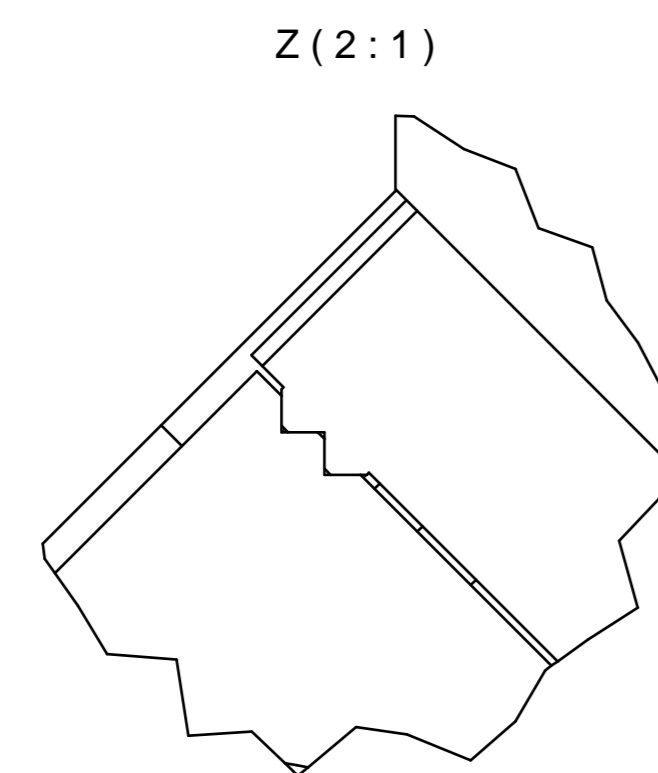
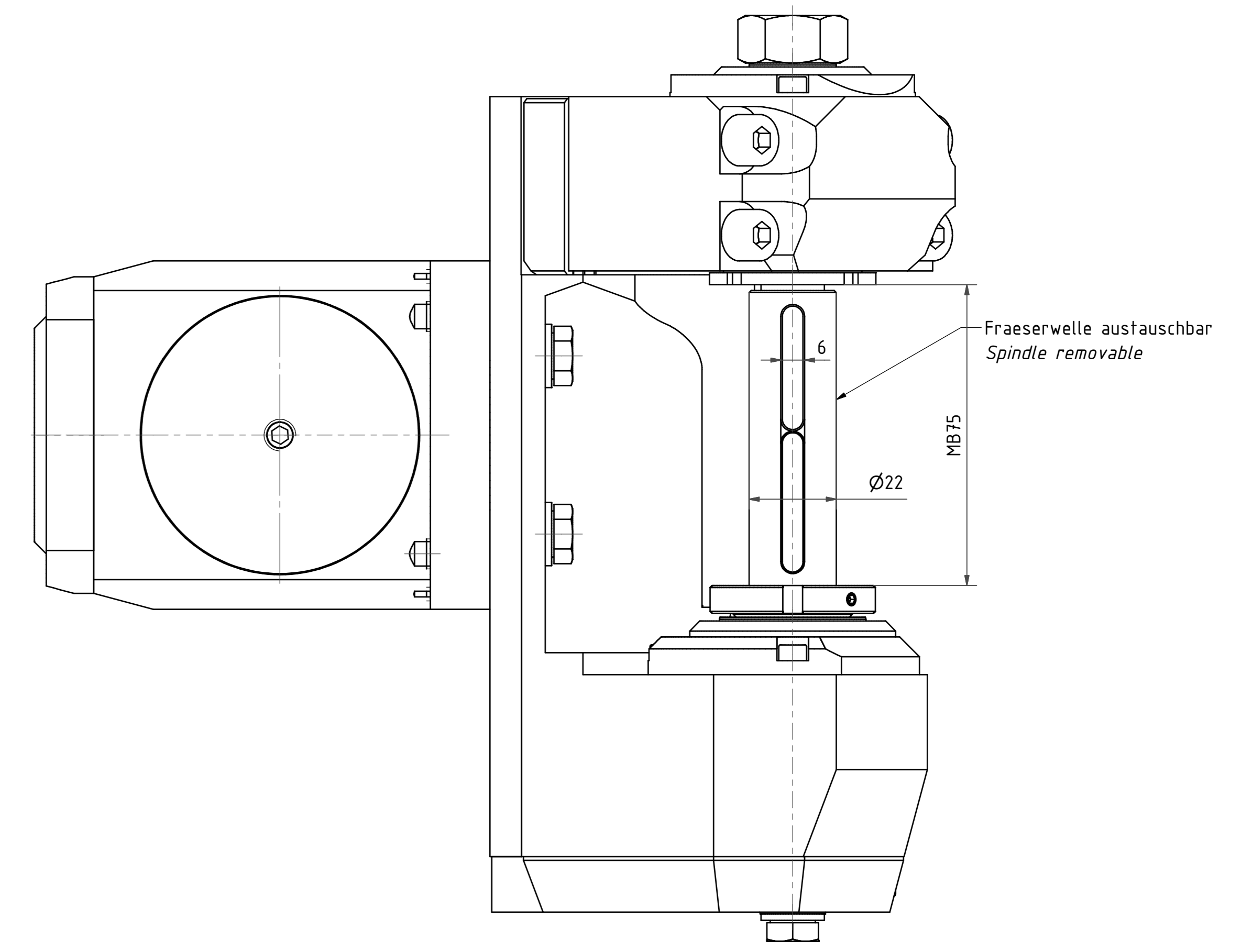
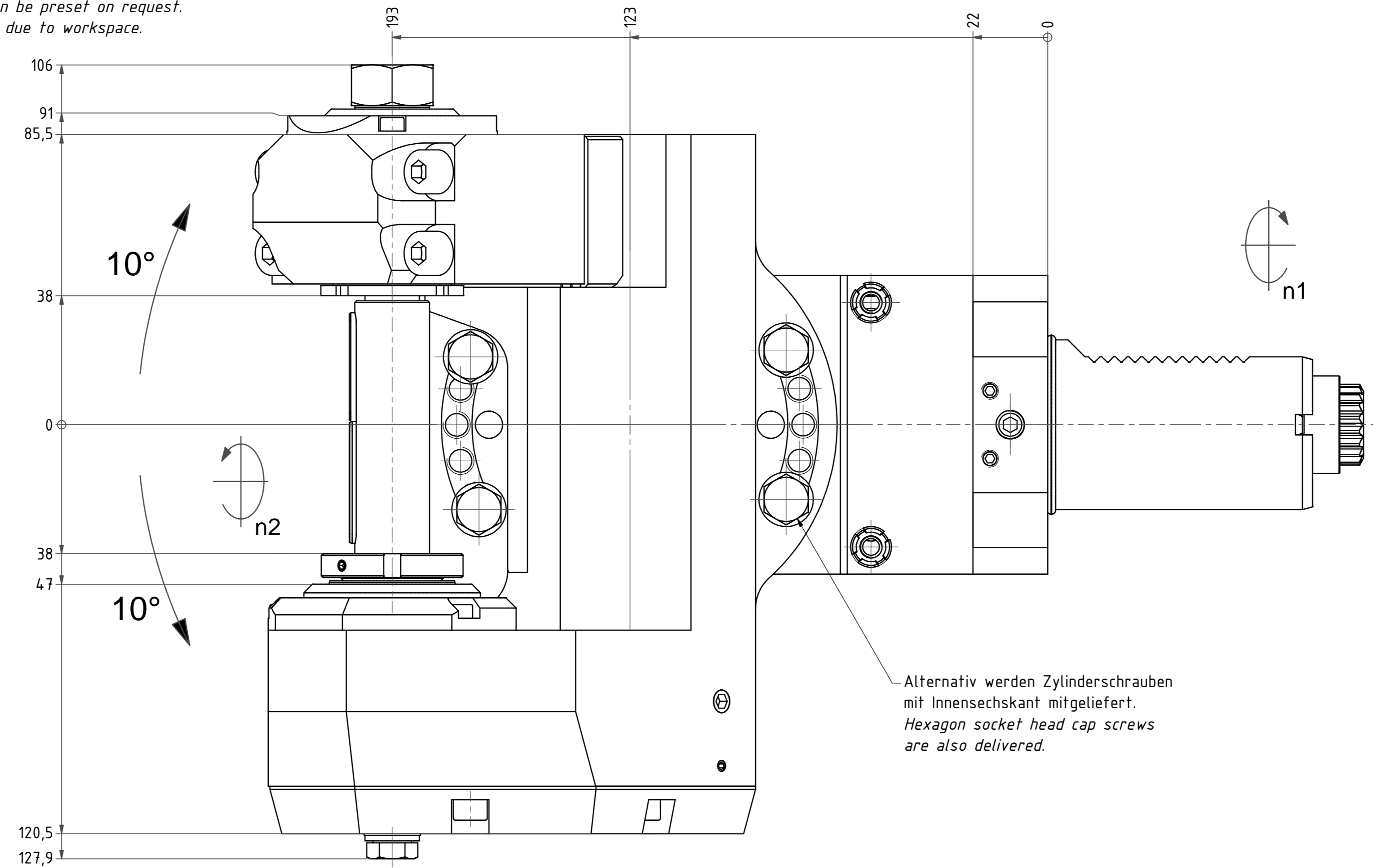
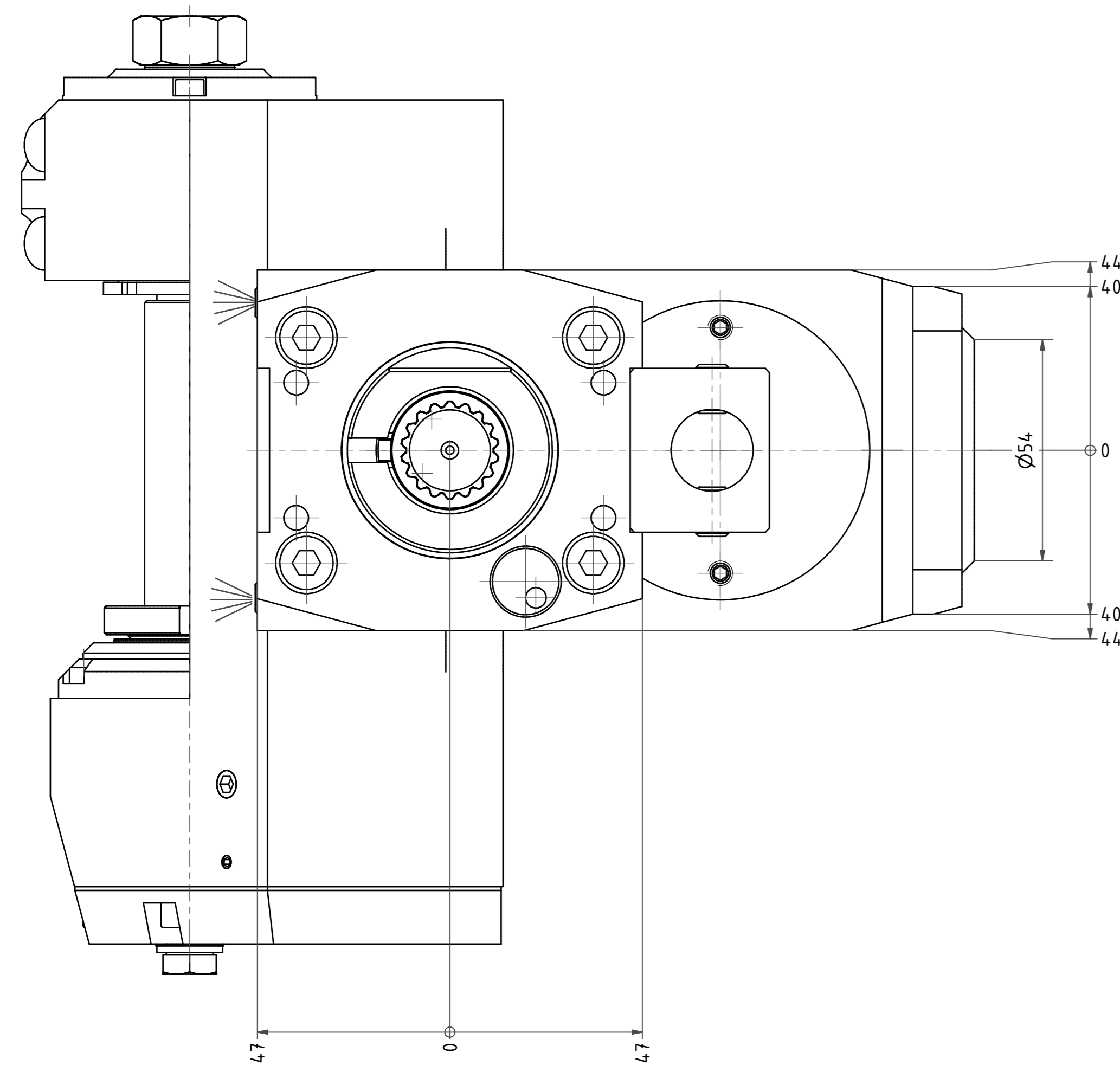

Beide Nachbarstationen könnten entfallen!  
both neighbouring stations may be lost!

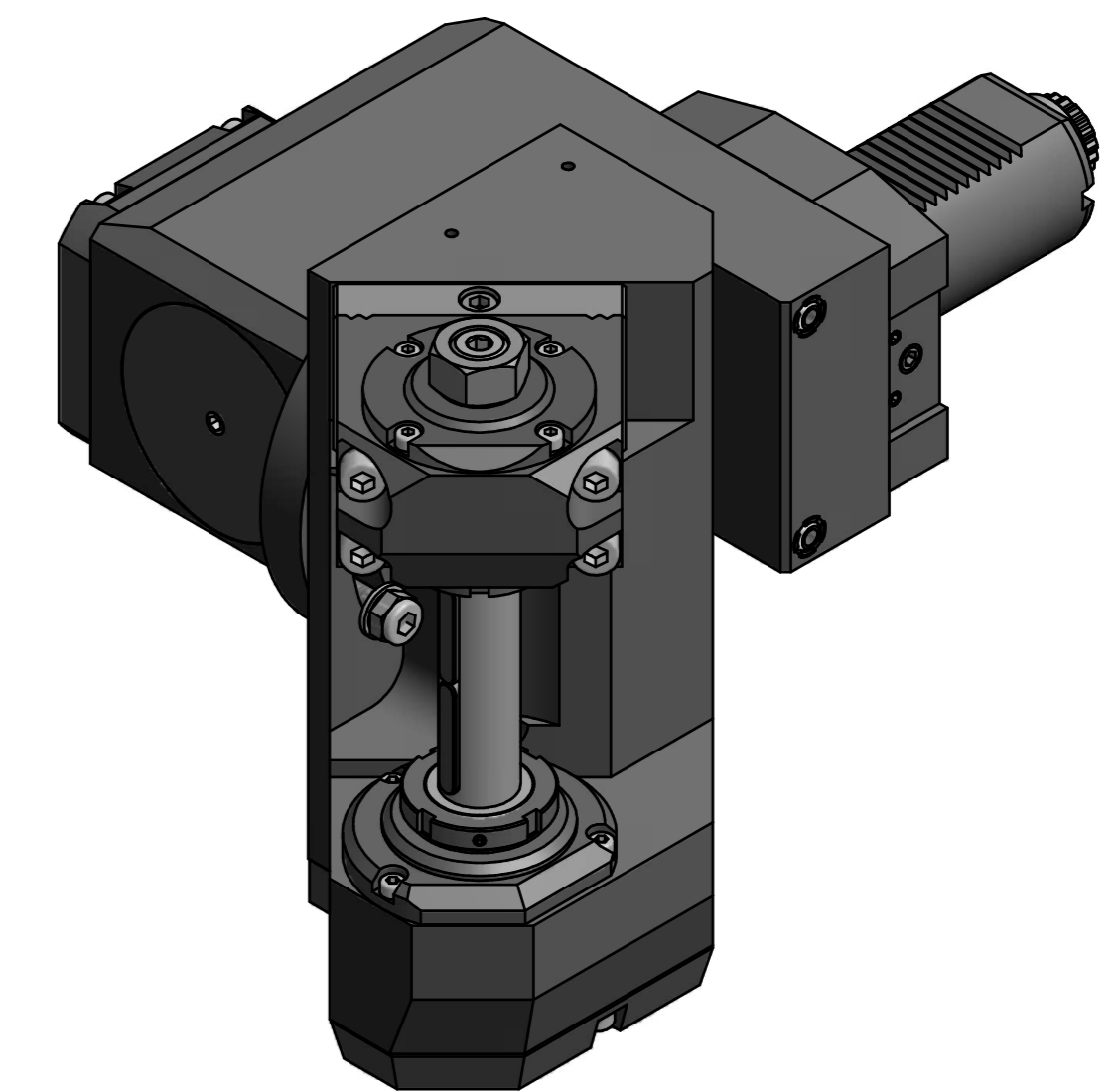

<p>Bezeichnung - Name</p>	<p>Technische Daten - Technical Data</p> <p>Weight = 25.443 (kg)</p> <p>Torque max. (M1/M2) = 50 / 100 (Nm)</p> <p>Speed max. (n1/n2) = 6000 / 3000 (1/min)</p> <p>Gear ratio (i)n1/n2 = 2:1</p>	<p>Abmessung - Size</p>	<p>Rechtliche Änderungen vorbehalten Subject to technical modifications!</p> <p>8261 - 0,4x3,7x203</p> <p>8511 - 0,7x...</p>	<p>Copyright EWS Tool Technologies Weitergabe und Vervielfältigung dieser Unterlage, Vervielfältigung und Missbrauch dieses Inhalts sind gestattet, soweit nicht ausdrücklich zugestanden. Zweckerhöhungen verpflichten zu Schutzerersatz.</p>	<p>QR</p>
<p>Radial Scheibenfräserkopf versetzt Saw milling spindle offset</p>		<p>84.50225480R2TKWZ63.5MB75-BG40 1584.18</p>			