

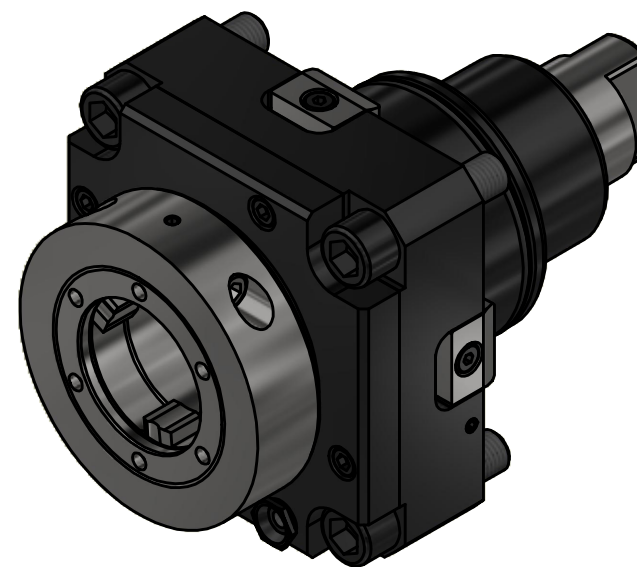

Ceramic Seal

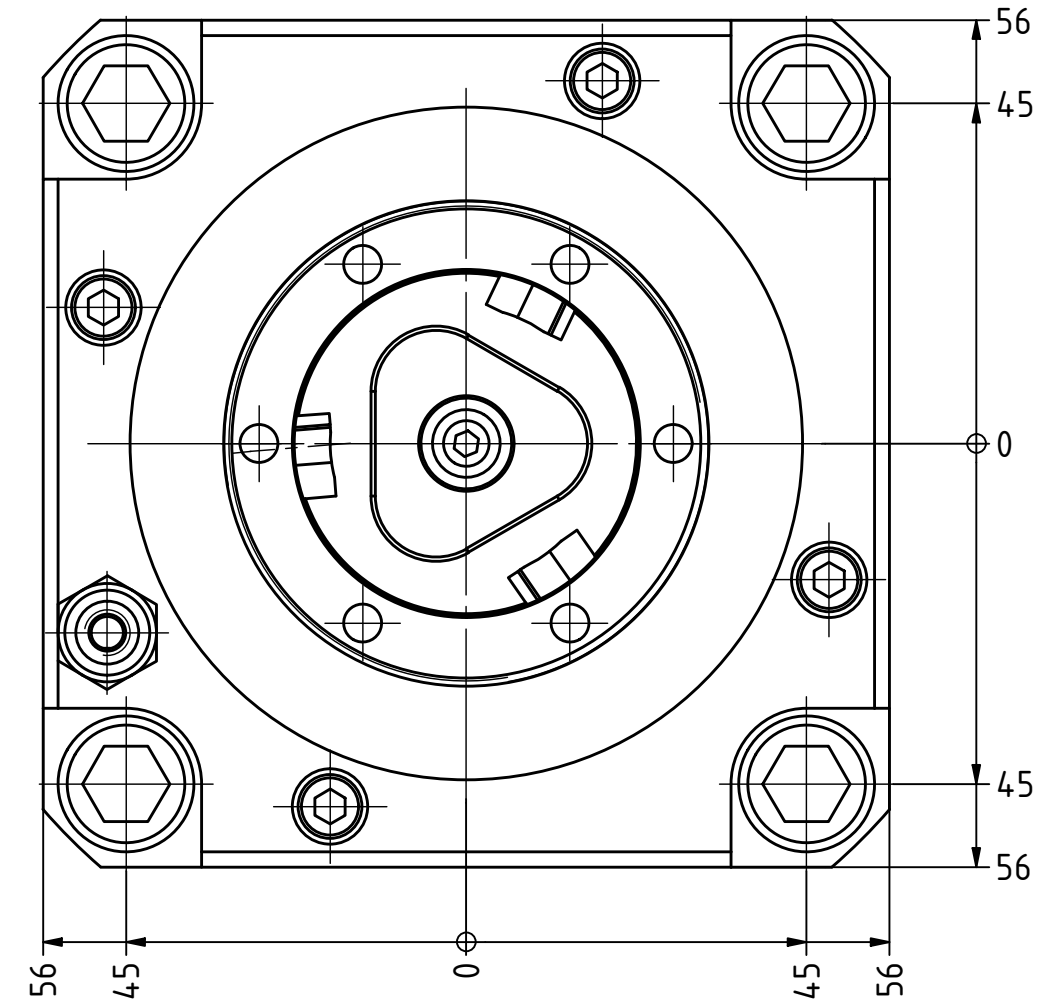

Tech Details

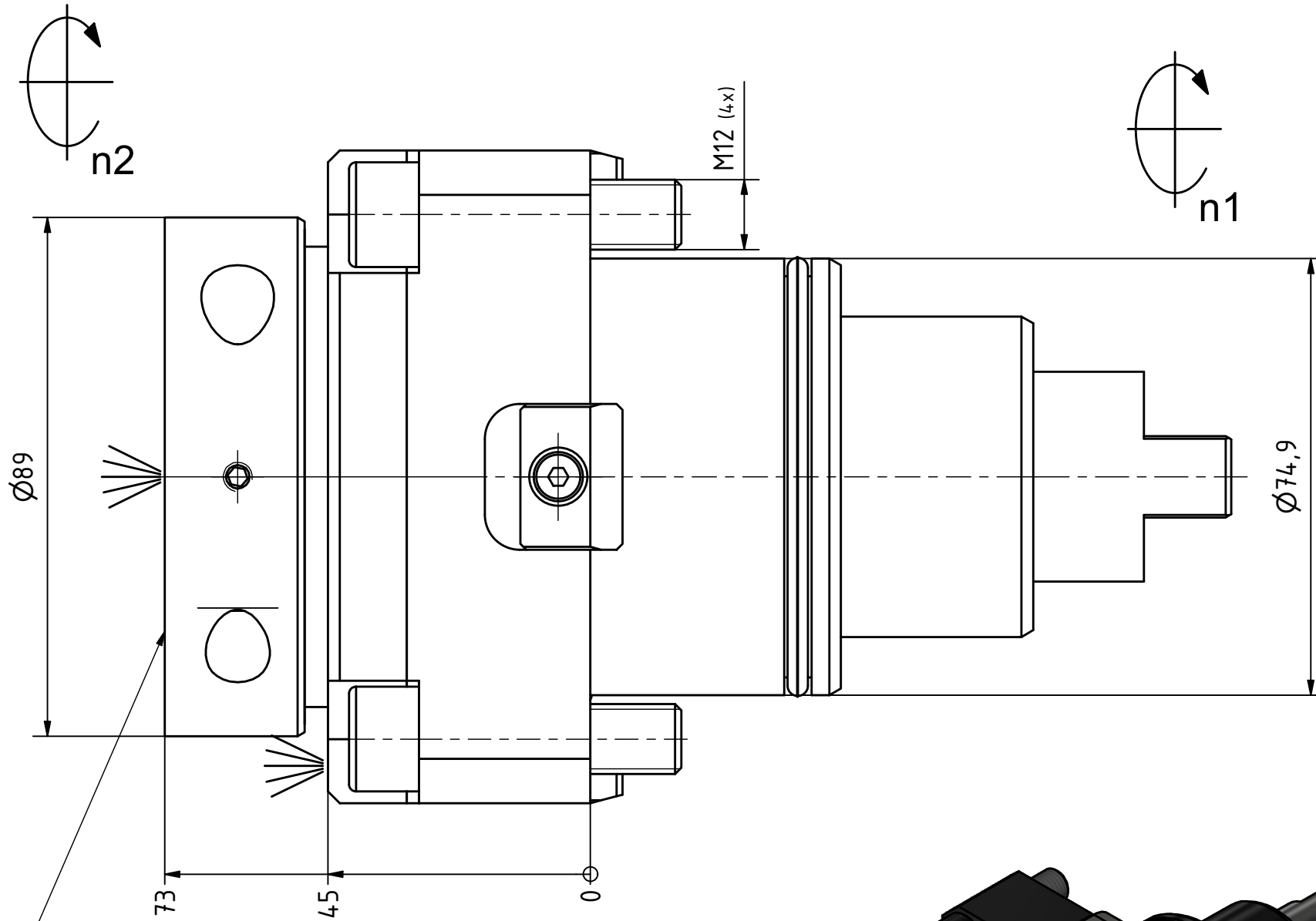

EWS-Varia V5

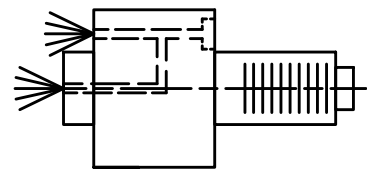

Innen- und Aussenkuehlung / Inside and outside coolant supply
Kuehlmittelfiltrierung-50µ / coolant filtration-50µ

Copyright **EWS Tool Technologies**
Weitergabe und Vervielfaeltigung dieser Unterlage,
Verwertung und Mitteilung ihres Inhalts nicht
gestattet, soweit nicht ausdrucklich zugestanden.
Zuwiderhandlungen verpflichten zu Schadenersatz.

Bemerkung - Note
Für Trockenlauf geeignet!
Use without coolant fluid allowed!

| Technische Daten - technical data | |
|-----------------------------------|-----------------------|
| Weight | = 6.329 [kg] |
| Torque max. (M1/M2) | = 100 / 100 [Nm] |
| Speed max. (n1/n2) | = 4000 / 4000 [1/min] |
| Gear ratio (i)=n1:n2 | = 1:1 |
| Pressure (pmax) | = 70 [bar] |

Benennung - Title
Axial Bohr und Fräskopf
Axial drilling and milling head



Nr. - No.
40.75V51809IKD

Technische Aenderungen vorbehalten!
Subject to technical modifications!
IDENT: DEWS251759

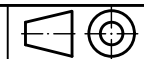

REV: -/A

MNR.
193207

