

Innen- und Aussenkuehlung / Inside and outside coolant supply
 Kein Trockenlauf / No dry run
 Kuehlmittelfiltrierung-50µ / coolant filtration-50µ

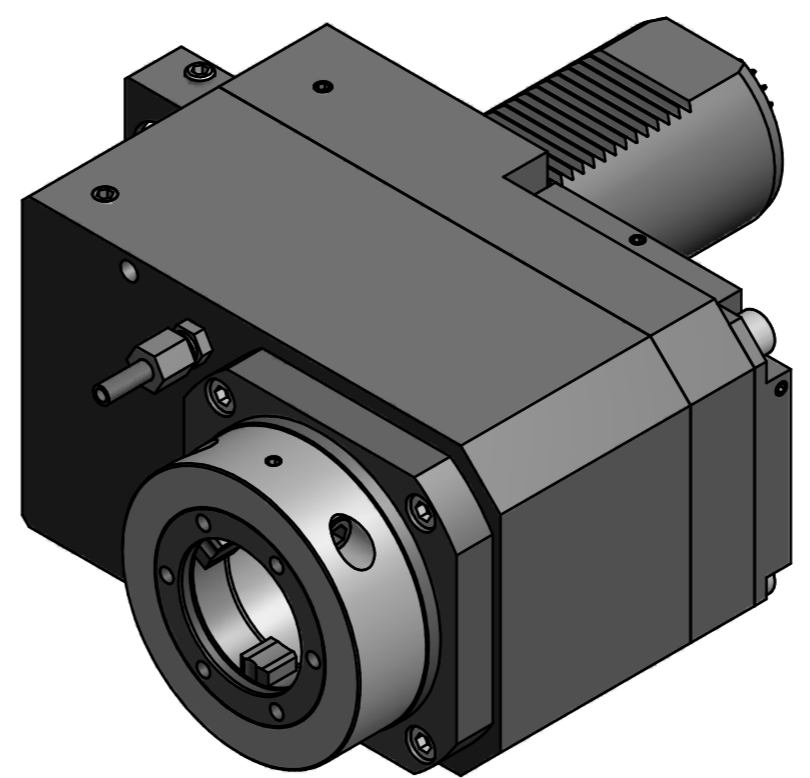

Copyright **EWS Tool Technologies**
 Weitergabe und Vervielfaeltigung dieser Unterlage,
 Verwertung und Mitteilung ihres Inhalts nicht
 gestattet, soweit nicht ausdruerecklich zugestanden.
 Zuwiderhandlungen verpflichten zu Schadenersatz.

Bemerkung - Note Nicht ohne Kuehlmittel betreiben! Not for use without coolant-fluid! mit Kegelrollenlager with taper roller bearing	Technische Daten - Technical data M1 / M2 = 80 / 160 Nm n1 / n2 = 4000 / 2000 1/min i (N1:N2) = 2:1 Pmax = 70 bar	Benennung - Title Axial Bohr u. Fräskopf achsversetzt <i>Ax. drill. and mill. head offset</i>	name Theiss	date 11.06.2014	Technische Aenderungen vorbehalten! Subject to technical modifications! Nr. 50.60V5KR5482RIK12 MNR: 157945 IDENT: D-EWS-157704 - Blatt - page 1 (1)	