

Spannzange / collet ER25 DIN6499
 Spannungsbereich / clamping range: 1,0 - 16,0

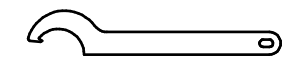

Hakenschlüssel
 mit Nase
 Hook wrench with
 nose end
 DIN1810 A 58x62

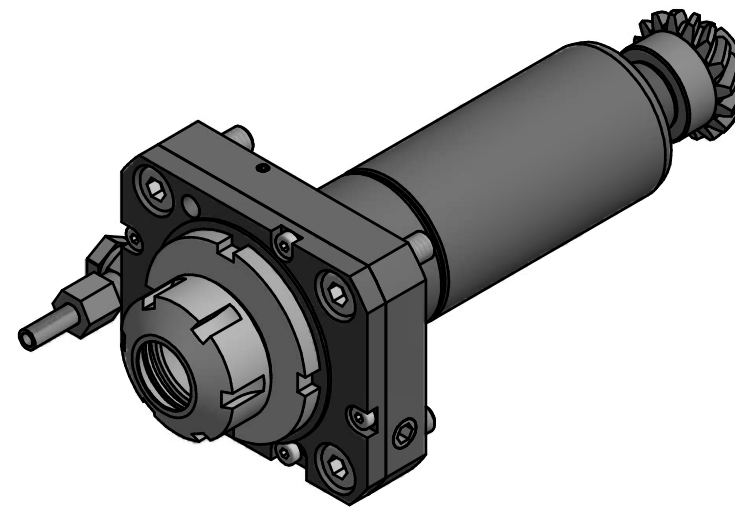
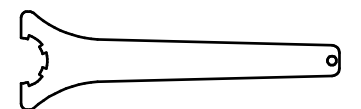

Spannzangenschlüssel
 Clamping wrench
 225

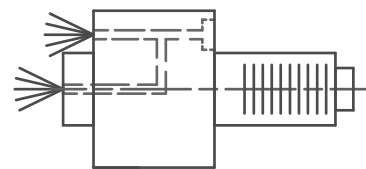

Innen- und Aussenkuehlung / Inside and outside coolant supply
 Kein Trockenlauf / No dry run
 Kuehlmittelfiltrierung <math>< 50\mu</math> / coolant filtration <math>< 50\mu</math>

Copyright **EWS Tool Technologies**
 Weitergabe und Vervielfaeltigung dieser Unterlage,
 Verwertung und Mitteilung ihres Inhalts nicht
 gestattet, soweit nicht ausdruuecklich zugestanden.
 Zuwiderhandlungen verpflichten zu Schadenersatz.

Bemerkung - Note
 Nicht ohne Kuehlmittel betreiben!
 Not for use without coolant-fluid!

Technische Daten - technical data
 Weight = 2.594 [kg]
 Torque max. (M1/M2) = 25 / 25 [Nm]
 Speed max. (n1/n2) = 6000 / 6000 [1/min]
 Gear ratio (i)=n1:n2 = 1:1
 Pressure (pmax) = 25 [bar]

Benennung - Title
 Axial Bohr und Fräskopf
 Axial drilling and milling head



Nr. - No.
 40.4525BNJIK

Technische Aenderungen vorbehalten!
 Subject to technical modifications!

IDENT: D-EWS-205481



REV: -/-

MNR.
 193287

