

Schwenkbereich ±105°  
Swivel area ±105°

Spannzange / collet ER25 DIN6499  
Spannbereich / clamping range: 1,0 - 16,0

Gewindebohrzange / tapping collet  
ET-1-25 M3-M10

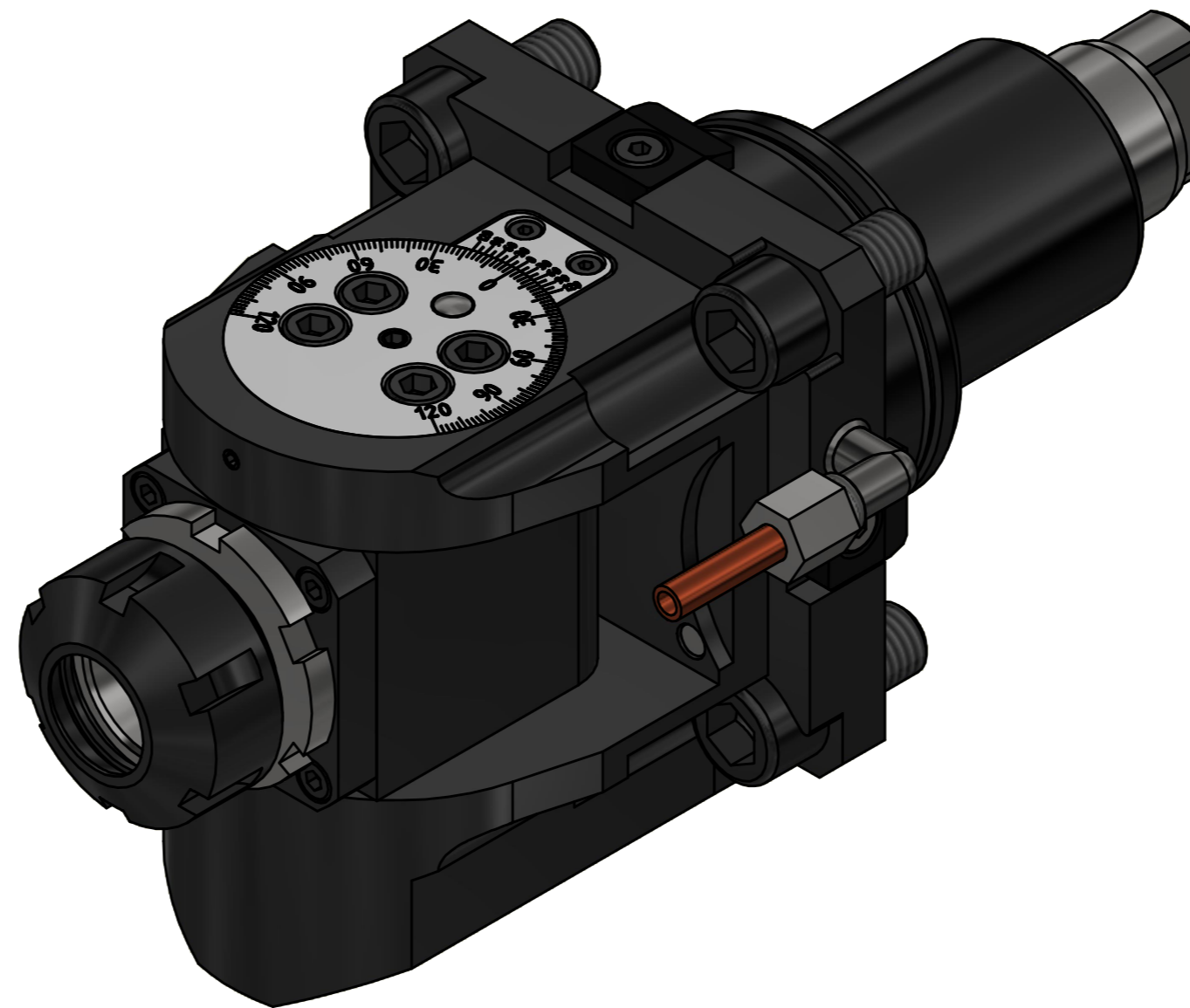
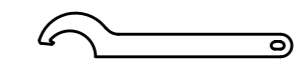

  
Hakenschlüssel  
mit Nase  
Hook wrench with  
nose end  
DIN1810 A 45x50

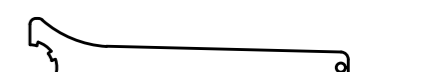
  
Spannzangenschlüssel  
Clamping wrench  
225

Bitte überprüfen Sie, ob der Werkzeughalter auf ihrem Revolver  
im Maschinenraum ohne Kollision durchschwenken kann.

Please check the work space of the machine for interferences  
with the tool holder, especially the swiveling diameter.

Eine Nachbarstation könnte entfallen!  
A neighbouring station may be lost!

Copyright **EWS Tool Technologies**  
Weitergabe und Vervielfältigung dieser Unterlage,  
Verwertung und Mitteilung ihres Inhalts nicht  
gestattet, soweit nicht ausdrücklich zugestanden.  
Zuwerhandlungen verpflichten zu Schadenersatz.

Bemerkung - Note	Technische Daten - technical data <b>Weight</b> = 2,921 [kg] <b>Torque max.</b> (M1/M2) = 20 / 20 [Nm] <b>Speed max.</b> (n1/n2) = 6000 / 6000 [1/min] <b>Gear ratio</b> (i)=n1:n2 = 1:1	Benennung - Title <b>Schwenkkopf</b> <b>Swivel head</b>	 <b>EWS</b> Weigle GmbH & Co. KG Maybachstr. 1 D-73066 Uhingen www.ews-tools.de	Technische Änderungen vorbehalten! Subject to technical modifications! IDENT: DEWS24141 REV: -/B MNR.	
Nr. - No. <b>63.6525VL6</b>		<b>192608</b>			