

Spannzange / collet ER32 DIN6499
Spannbereich / clamping range: 2,0 - 20,0

Gewindebohrzange / tapping collet
ET-1-32 M5-M12

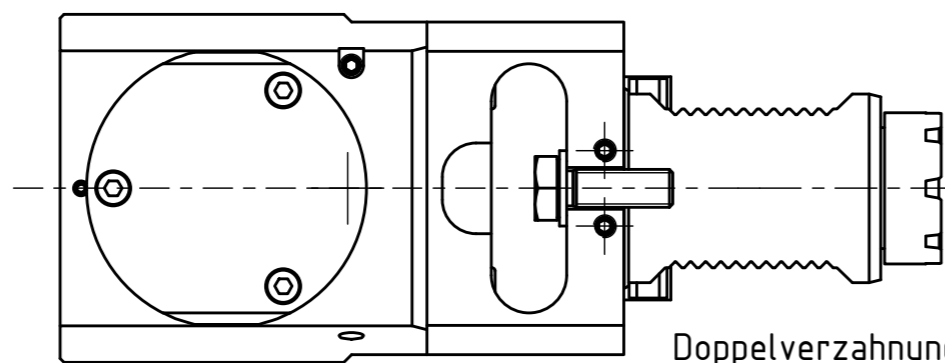

Doppelverzahnung Lizenz Traub
double tooth system licence Traub

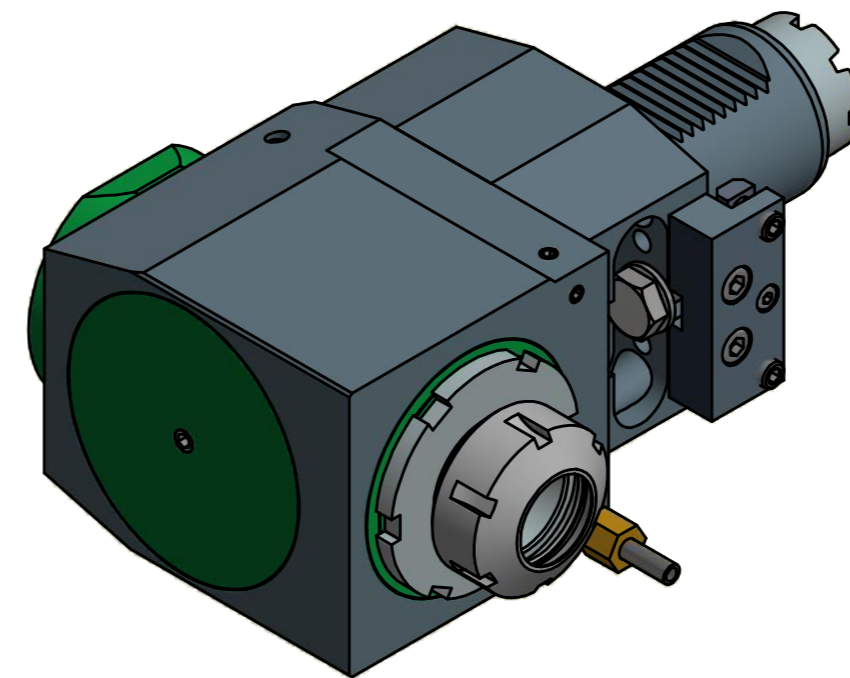

Spannzangenschlüssel
Clamping wrench
232

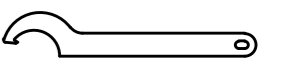

Hakenschlüssel
mit Nase
Hook wrench with
nose end
DIN1810 A 68x75

Copyright **EWS Tool Technologies**
Weitergabe und Vervielfältigung dieser Unterlage,
Verwertung und Mitteilung ihres Inhalts nicht
gestattet, soweit nicht ausdrücklich zugestanden.
Zuwendungen verpflichten zu Schadenersatz.

Bemerkung - Note

Technische Daten - technical data

Weight = 9.639 [kg]
Torque max. (M1/M2) = 100 / 50 [Nm]
Speed max. (n1/n2) = 4000 / 8000 [1/min]
Gear ratio (i)=n1:n2 = 1:2

Benennung - Title

Radial Bohr und Fräskopf
Radial drilling and milling head



Technische Änderungen vorbehalten!
Subject to technical modifications!

IDENT: DEWS032637

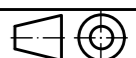

REV: -/A

Nr. - No.
60.5032TOEMRL1X105

MNR.
163713

QR