

Spannzange / collet ER25 DIN6499  
Spannbereich / clamping range: 1,0 - 16,0

Gewindebohrzange / tapping collet  
ET-1-25 M3-M12

Spannzange / collet ER25 DIN6499  
Spannbereich / clamping range: 1,0 - 16,0

Gewindebohrzange / tapping collet  
ET-1-25 M3-M12

Hakenschlüssel mit Nase  
Hook wrench with nose  
DIN1810 A 52x55

Spannzangenschlüssel für innenliegende Mutter  
Clamping wrench for internal collet  
225AX

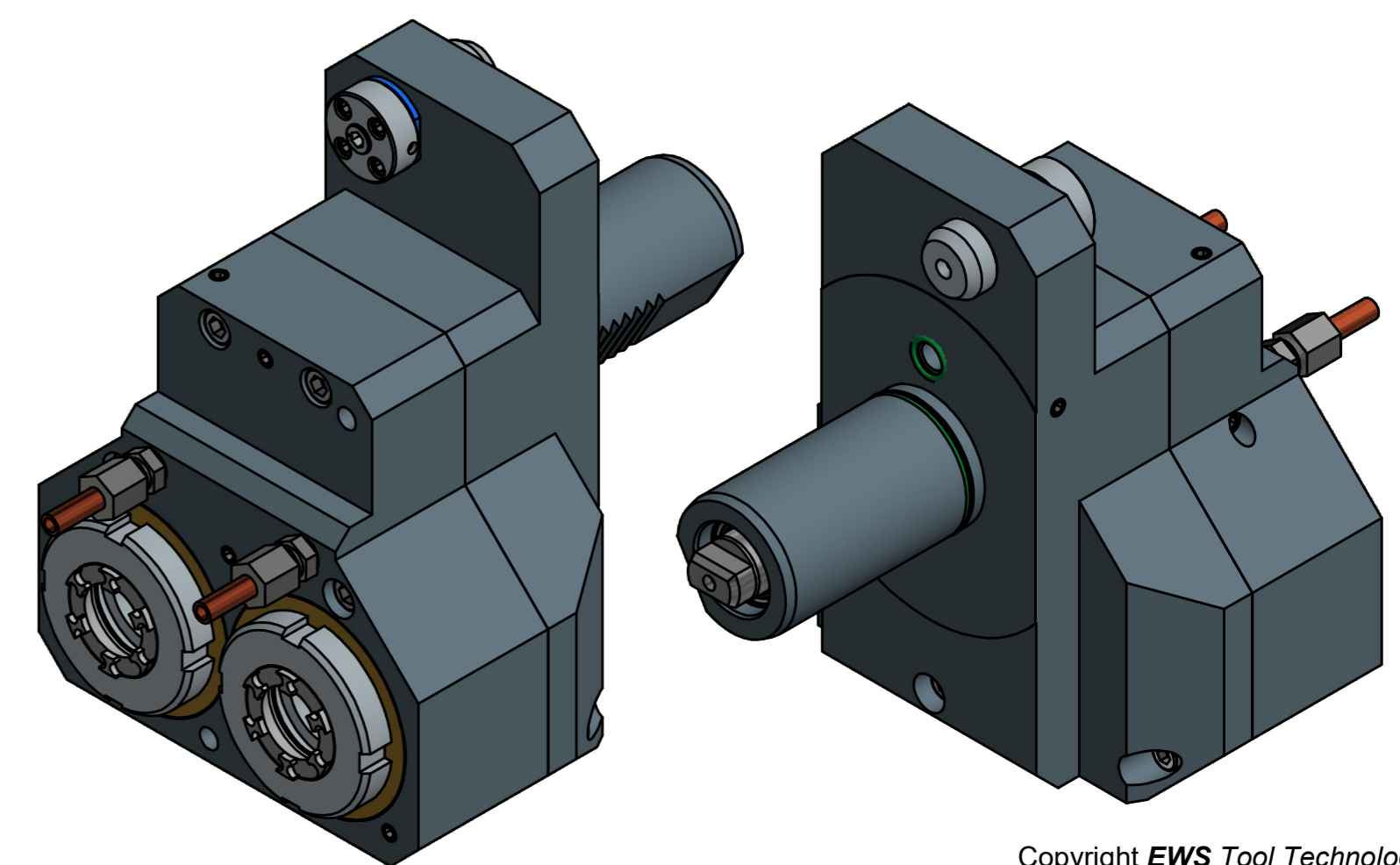
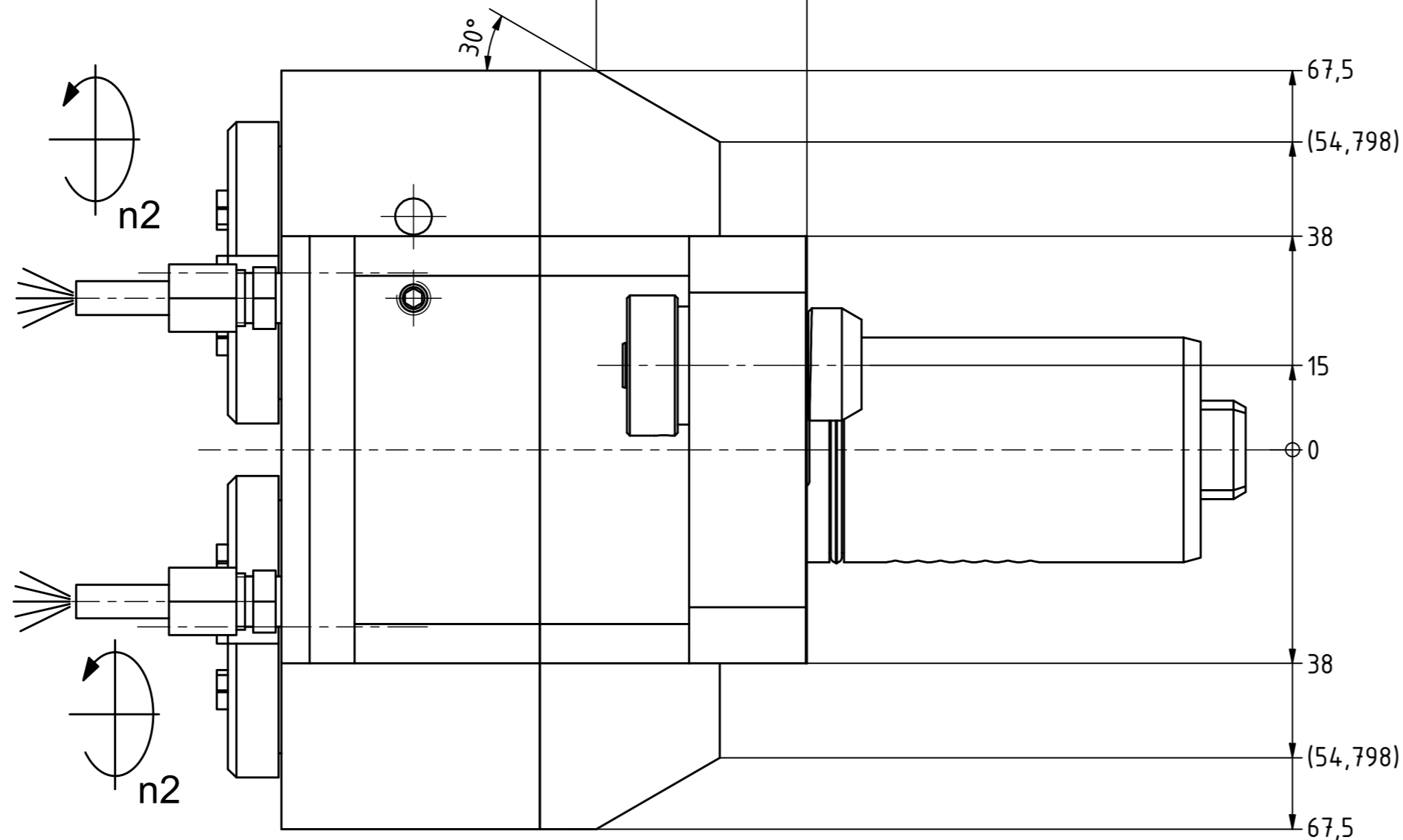

Copyright EWS Tool Technologies  
Weitergabe und Vervielfältigung dieser Unterlage, Verwertung und Mitteilung ihres Inhalts nicht gestattet, soweit nicht ausdrücklich zugestanden. Zuwiderhandlungen verpflichten zu Schadenersatz.

Bemerkung - Note Benennung - Title	Technische Daten - technical data Weight = 9,410 [kg] Torque max. (M1/M2) = 50 / 50 [Nm] Speed max. (n1/n2) = 6000 / 6000 [1/min] Gear ratio (i)=n1:n2 = 1:1	Axial Bohr u. Fräskopf achsversetzt Ax. drill. and mill. head offset	EWS Weigle GmbH & Co. KG Maybachstr. 1 D-73066 Ulm/ingen www.ews-tools.de	Technische Änderungen vorbehalten! Subject to technical modifications! IDENT: DEWS016829 Nr. - No. 50.4025DYSQT15RIMTK63	REV: -/A MNR. 200532 
---------------------------------------	--	---	--	--	--------------------------------