

56,5
50
0
24
75
126

Ø89
Ø50

136
114
102,85
61,5
27
14,5
0

ABS 50
(Lizenz Komet)

30°
27
53,5
48
0
48
53,5

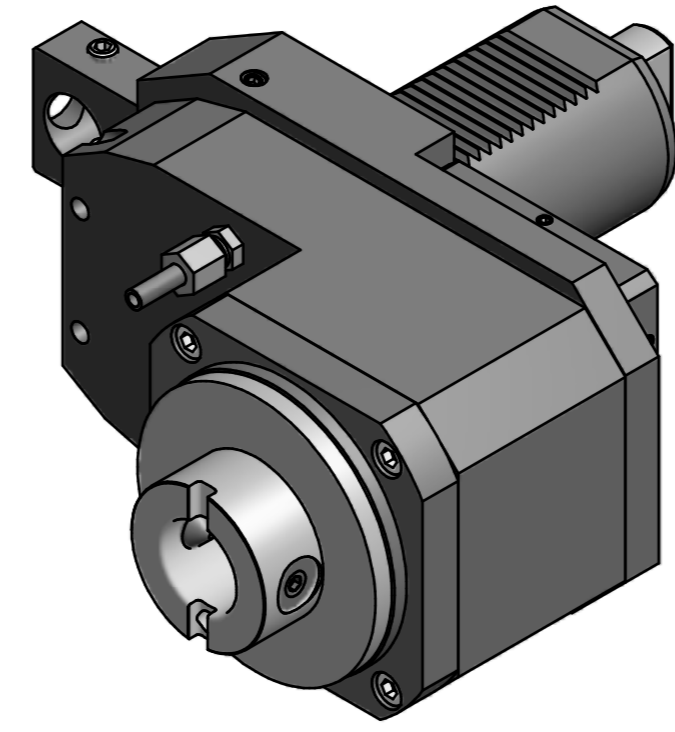

Copyright **EWS Tool Technologies**
Weitergabe und Vervielfältigung dieser Unterlage,
Verwertung und Mitteilung ihres Inhalts nicht
gestattet, soweit nicht ausdrücklich zugestanden.
Zu widerhandlungen verpflichten zu Schadenersatz.

Bemerkung - Note	Technische Daten - technical data		Benennung - Title	name	date	Technische Änderungen vorbehalten! Subject to technical modifications!				
	mit Kegelrollenlager with taper roller bearing(s)						M ₁ / M ₂ = 160 / 160 Nm	Axial Bohr u. Fräskopf achsversetzt Ax. drill. and mill. head offset	EWS EWS Weigte GmbH & Co. KG Maybachstr. 1 D-72096 Löhningen Tel. +49(0)7161/93040-100	Nr. 50.60ABS50KR1809R
							n ₁ / n ₂ = 3000 / 3000 1/min i (N ₁ :N ₂) = 1:1			
				MNR: 175630	IDENT: D-EWS-161546 -	Blatt - page 1 (1)				