

Spannzange / collet ER25 DIN6499  
 Spannungsbereich / clamping range: 1,0 - 16,0

Gewindebohrzange / tapping collet  
 ET-1-25 M3-M12

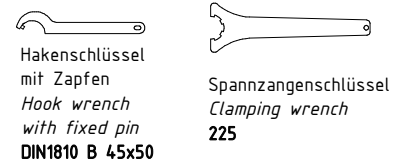
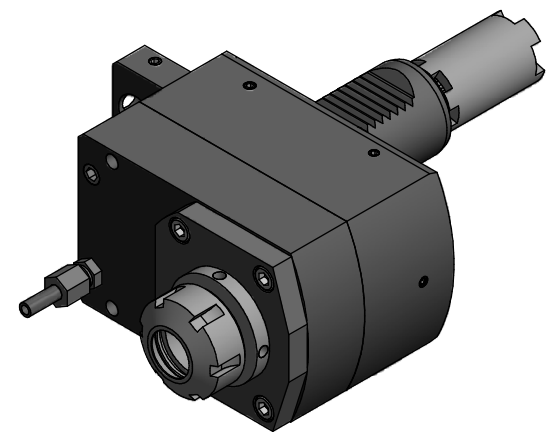
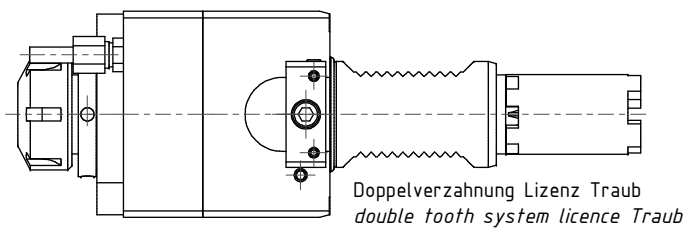

Copyright EWS Tool Technologies  
 Weitergabe und Vervielfältigung dieser Unterlage, Verwertung und Mitteilung ihres Inhalts nicht gestattet, soweit nicht ausdrücklich zugestanden. Zuwiderhandlungen verpflichten zu Schadenersatz.

Bemerkung - Note  	Technische Daten - Technical data Weight = 6.547 [kg] Torque max. (M1/M2) = 50 / 25 [Nm] Speed max. (n1/n2) = 6000 / 12000 [1/min] Gear ratio (i)=n1:n2 = 1:2	Bemerkung - Title  	 EWS Werkzeug GmbH & Co. KG D-72088 Löhningen www.ews-tool.de	Technische Änderungen vorbehalten! Subject to technical modifications! IDENT: DEWS00647 REV: -/A 1/18	
--------------------------	---	---------------------------	--	---	--

50.4025HAASSL40RL1

200505