

Spannzange / Collet ER16 DIN6499
 Spannungsbereich / Clamping range: 1,0 - 10,0

Gewindebohrzange / Tapping Collet
 ET-1-16 M1-M6

Fettschmierung mit Klüber Isoflex NCA 15
 Alle 100 Betriebsstunden mit ca. 1cm³ Fett nachschmieren
*Grease lubrication with Klüber Isoflex NCA 15
 relubricate every 100 operating hours with about 1cm³ of grease*

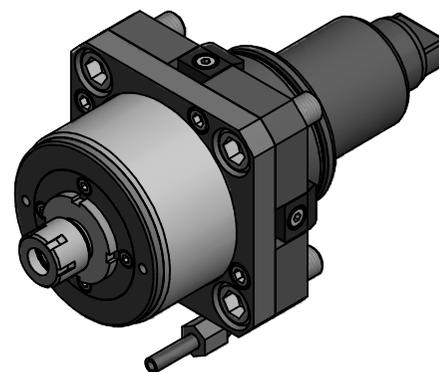

 Hakenschlüssel
 mit Nase
 Hook wrench with
 nose end
 DIN1810 A 36x38

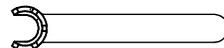
 Spannzangenschlüssel
 Clamping wrench
 216 M

Copyright **EWS Tool Technologies**
 Weitergabe und Vervielfältigung dieser Unterlage,
 Verwertung und Mitteilung ihres Inhalts nicht
 gestattet, soweit nicht ausdrücklich zugestanden.
 Zuwiderhandlungen verpflichten zu Schadenersatz.

| | | | | | | |
|------------------|--|-------------------|---|--|---|---|
| Bemerkung - Note | Technische Daten - technical data Weight = 4,227 [kg] Torque max. (M1/M2) = 25 / 5 [Nm] Speed max. (n1/n2) = 4800 / 24000 [1/min] Gear ratio (i)=n1:n2 = 1:5 | Benennung - Title |  EWS Weigelt GmbH & Co. KG Maybachstr. 1 D-73066 Uhingen www.ews-tools.de | Technische Änderungen vorbehalten! Subject to technical modifications! IDENT: DEWS004876 |  REV: -/A MNR. |  |
| | | | Nr. - No. 40.6516VL6115 | | 200045 | |