

Winkelausrichtung & CD-ROM
in Lieferung enthalten!
Angle adjusting & CD-ROM
included in delivery!

Z (2:1)

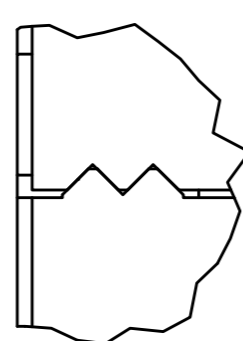

Gewindebohrungen für Winkelausrichtung.
Thread holes for angle adjusting.

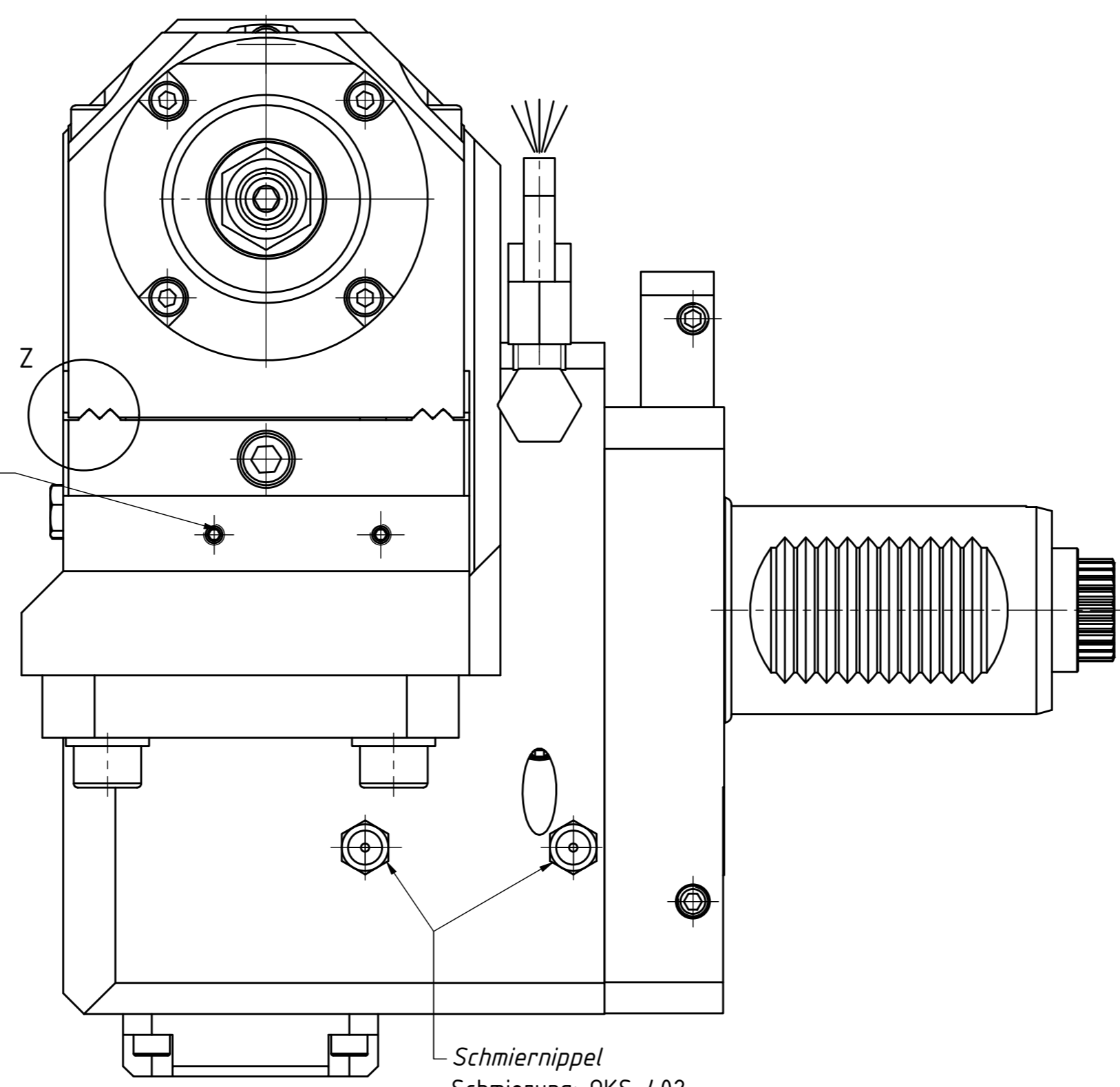

Schmiernippel
Schmierung: OKS-402

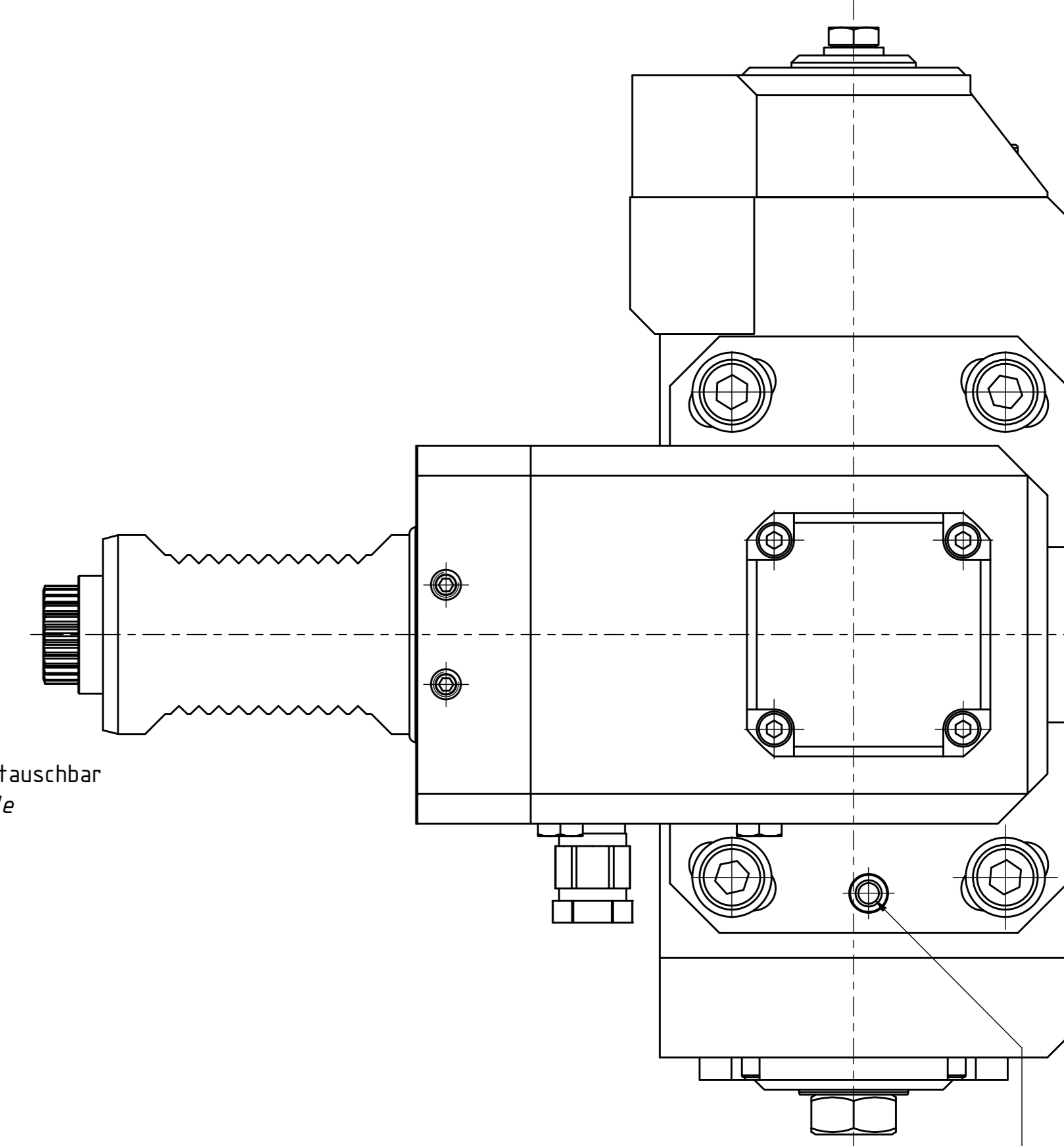
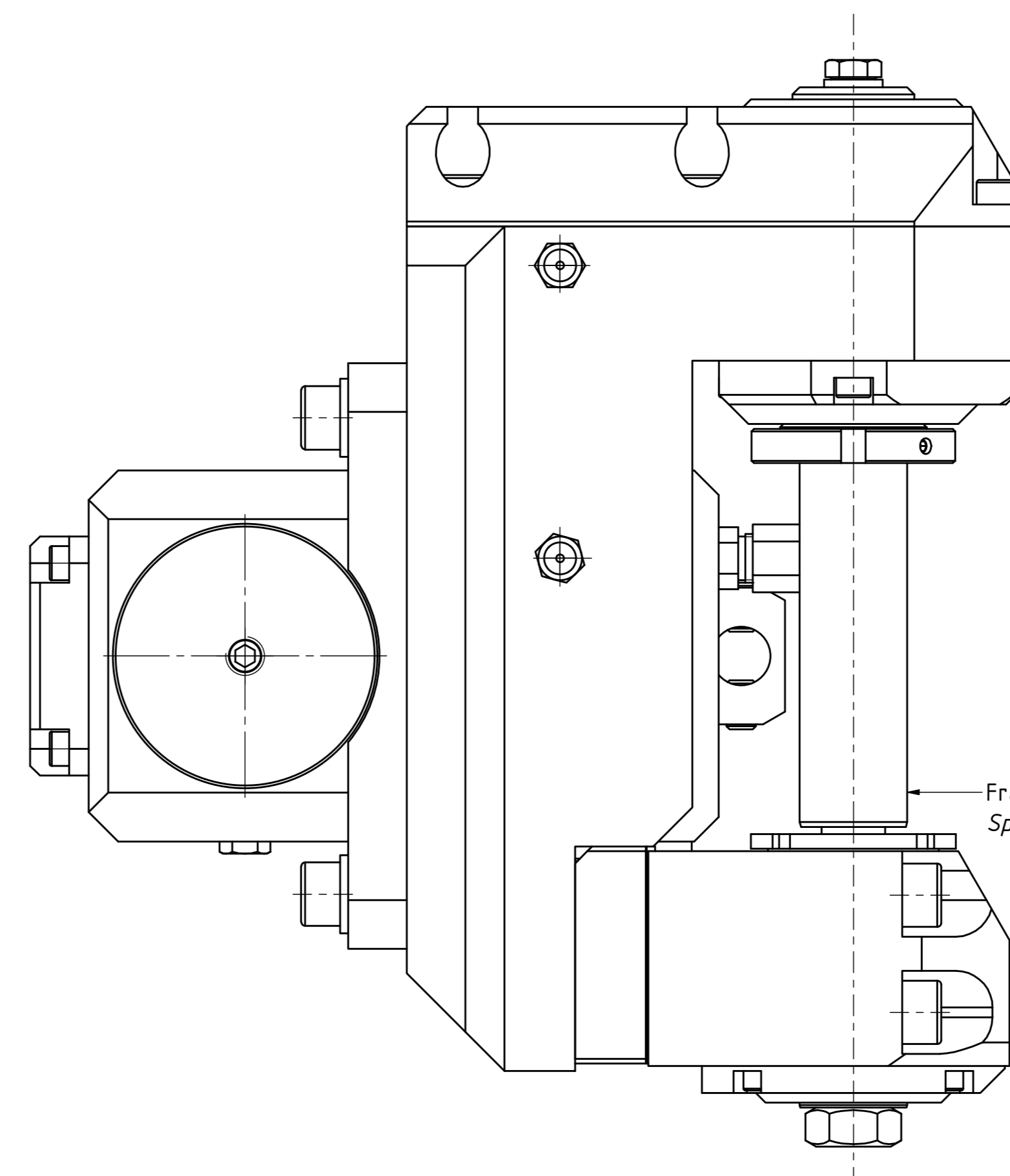
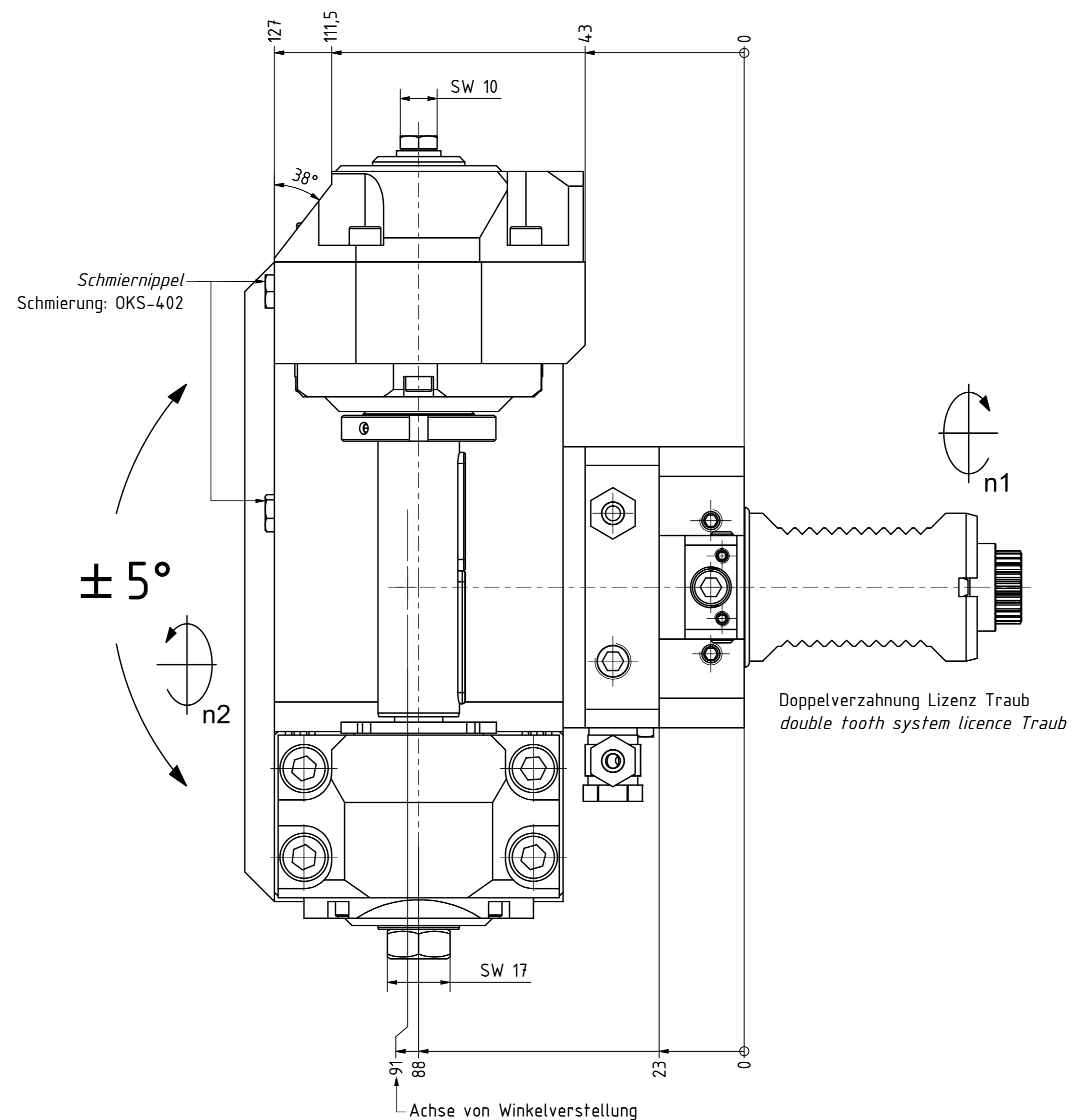
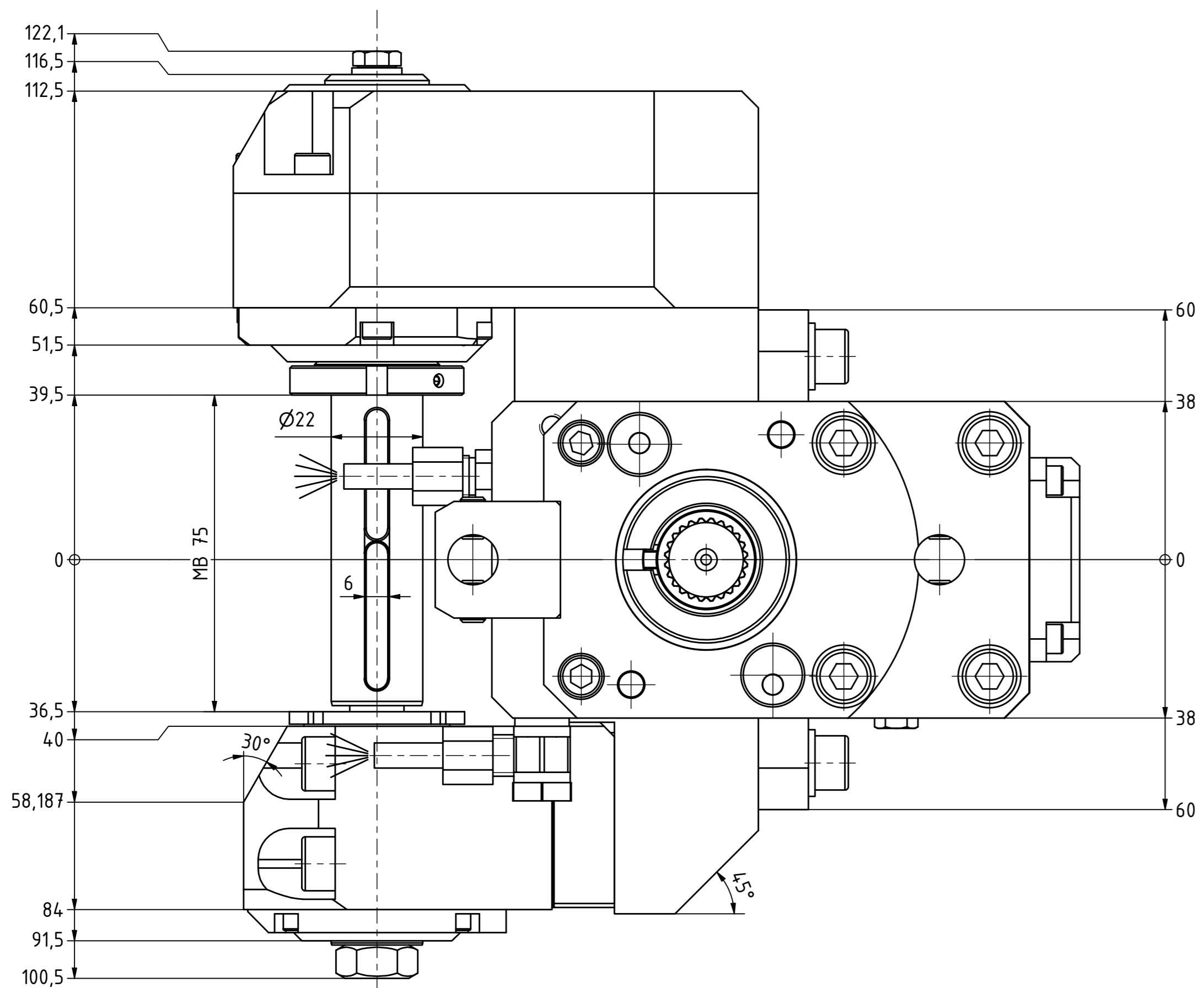

Bei Festwinkel Verstellungs-
möglichkeit durch Benutzer.

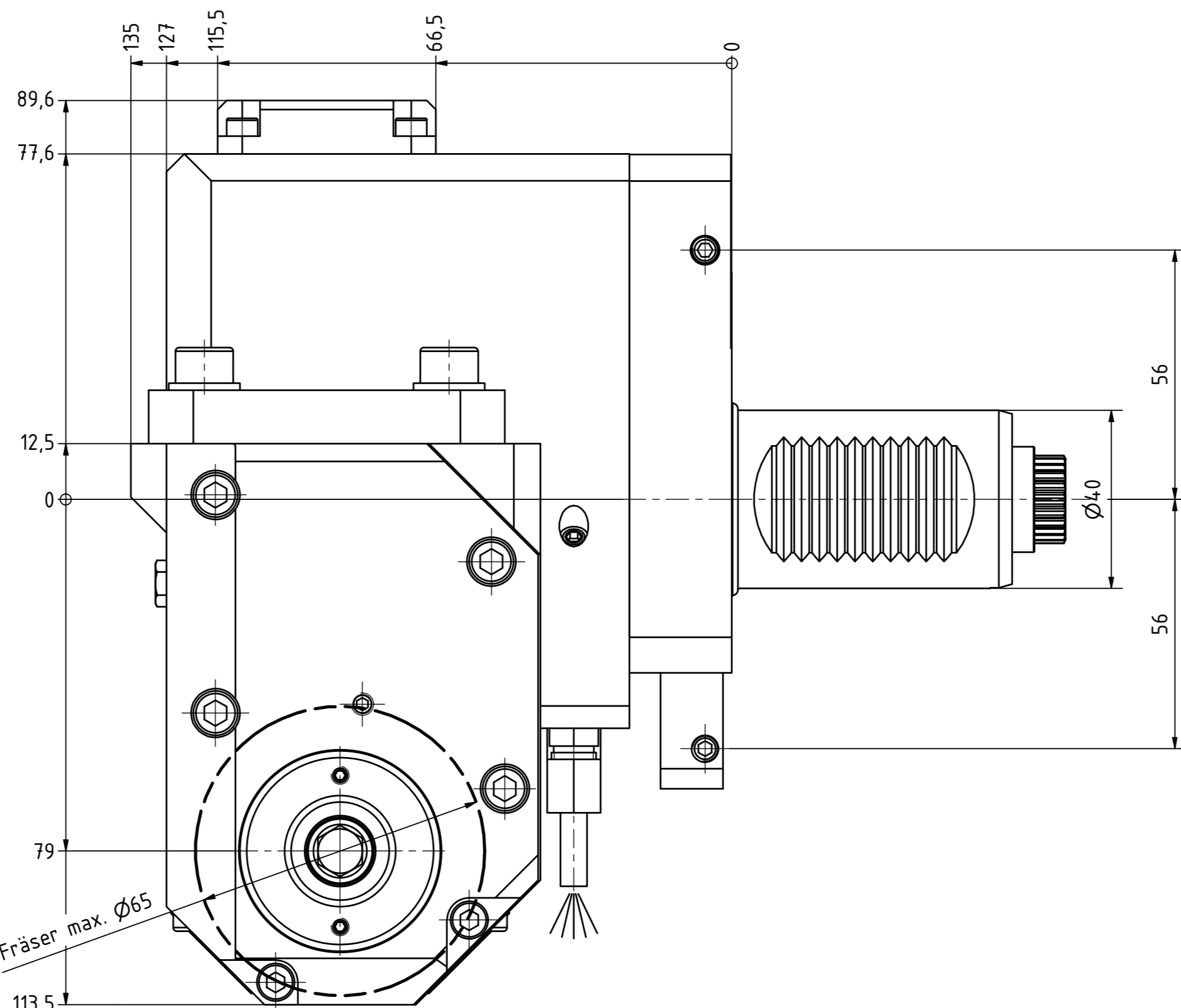
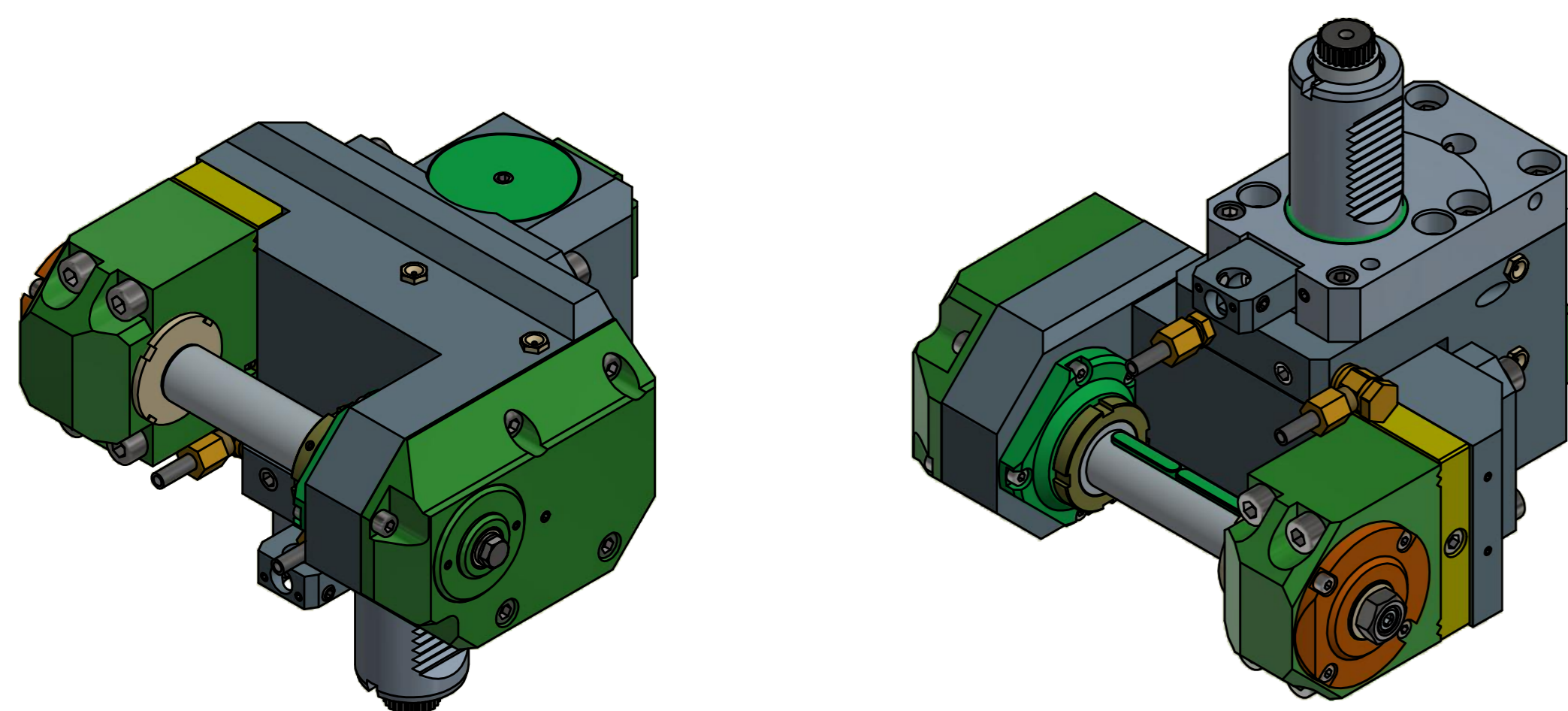

Beide Nachbarstationen nicht verwendbar!
Both neighbour stations are not useable!

Technische Daten - Technical data	Weight = 13,033 (kg)
	Torque max (n1/n2) = 4,0 / 80 (Nm)
	Speed max (n1/n2) = 6000 / 3000 (1/min)
	Gear ratio (i)=n1/n2 = 2:1

Radial Scheibenfräserkopf versetzt
Saw milling spindle offset

EWS	Technische Änderungen vorbehalten! Subject to technical modifications!
84_4022CTXRLI2TKWZ79MB75	REV: 07B
192527	192527



Copyright EWS Tool Technologies
Weitergabe und Vervielfältigung dieser Unterlagen,
Vervielfältigung und Mitteilung ohne schriftliche
Genehmigung, soweit nicht ausdrücklich zugestanden,
Zusammenfassungen vorbehalten zu Schadenersatz.