

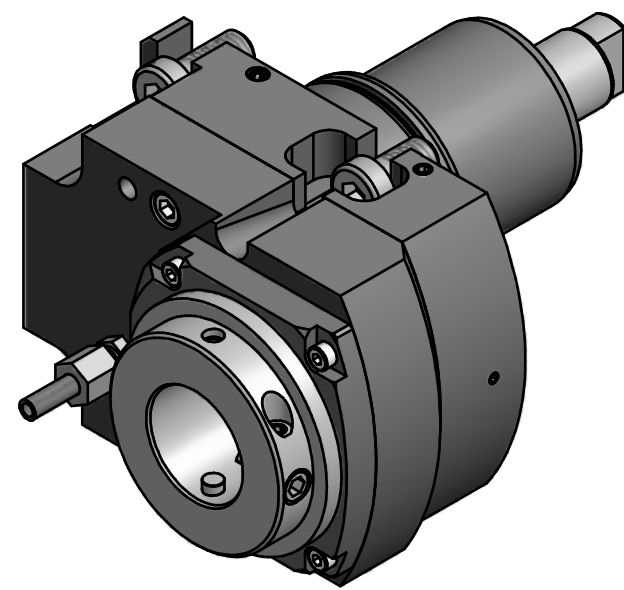

EWS-Varia V4

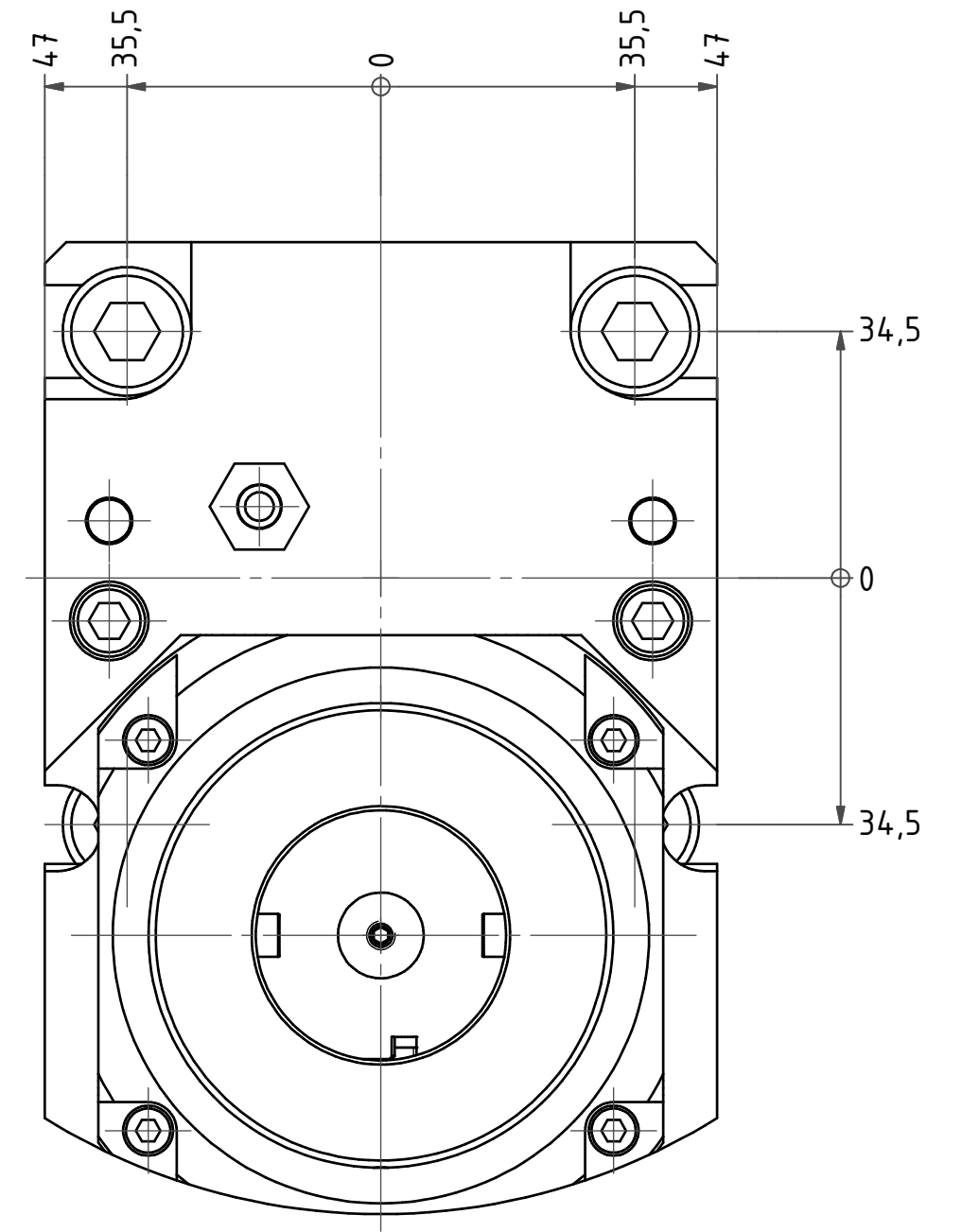
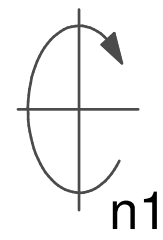

Copyright **EWS Tool Technologies**
 Weitergabe und Vervielfältigung dieser Unterlage,
 Verwertung und Mitteilung ihres Inhalts nicht
 gestattet, soweit nicht ausdrücklich zugestanden.
 Zuwiderhandlungen verpflichten zu Schadenersatz.

Bemerkung - Note	Technische Daten - Technical data		Benennung - Title		 EWS Weigete GmbH & Co. KG Maybachstr. 1 D-72096 Ulm/lingen Tel. +49(0)7161/93040-100	Technische Änderungen vorbehalten! Subject to technical modifications! Nr. 50.65V4 TW20 MNR: 174922 IDENT: D-EWS-156955 - Blatt - page 1 (1)	 DIN A2
	M ₁ / M ₂ = 50 / 50 Nm n ₁ / n ₂ = 6000 / 6000 1/min i (N ₁ :N ₂) = 1:1	Axial Bohr u. Fräskopf achsversetzt Ax. drill. and mill. head offset					

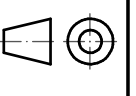
name M.Wiesenberg date 27.05.2014

