

 Spanzangenschlüssel
Clamping wrench
 225

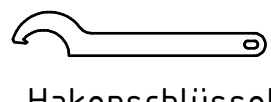

 Hakenschlüssel
 mit Nase
*Hook wrench with
 nose end*
 DIN1810 A 52x55

Spanzange / collet ER25 DIN6499
 Spannbereich / clamping range: 1,0 - 16,0

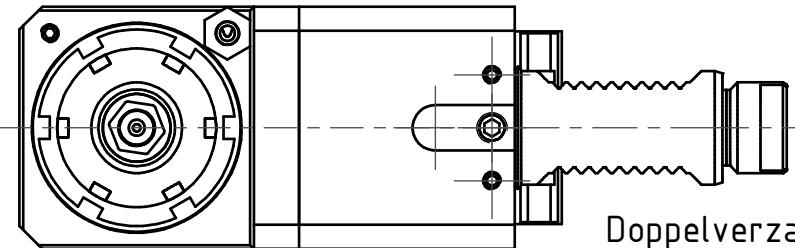

Gewindebohrzange / tapping collet
 ET-1-25 M3-M12

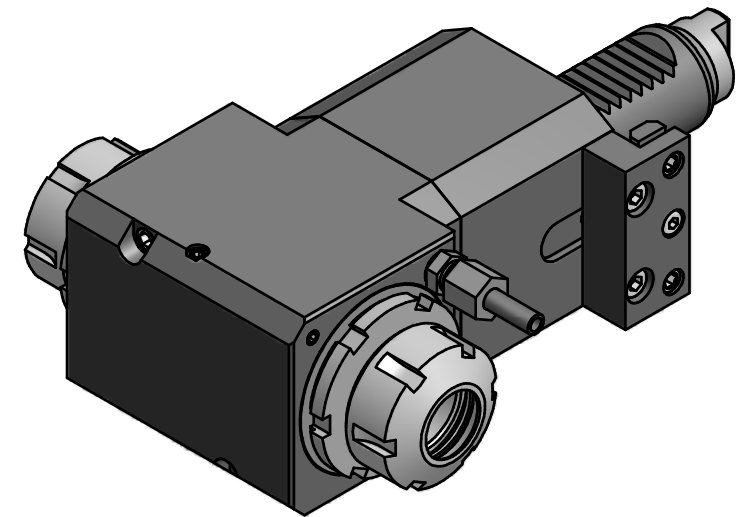

Doppelverzahnung Lizenz Traub
double tooth system licence Traub



Copyright **EWS Tool Technologies**
 Weitergabe und Vervielfaeltigung dieser Unterlage,
 Verwertung und Mitteilung ihres Inhalts nicht
 gestattet, soweit nicht ausdrecklich zugestanden.
 Zuwiderhandlungen verpflichten zu Schadenersatz.

Bemerkung - Note	Technische Daten - technical data Weight = 4.779 [kg] Torque max. (M1/M2) = 25 / 25 each Sp. [Nm] Speed max. (n1/n2) = 8000 / 8000 [1/min] Gear ratio (i)=n1:n2 = 1:1	Benennung - Title Radial Bohr und Fräskopf <i>Radial drilling and milling head</i>	 EWS Weigele GmbH & Co. KG Maybachstr. 1 D-73066 Uthingen www.ews-tools.de	Technische Aenderungen vorbehalten! <i>Subject to technical modifications!</i> IDENT: D-EWS-167717	 REV: B/- MNR. 163621	
			Nr. - No. 60.3025DTC600RLX100A35			