

Spannzange / collet ER32 DIN6499
 Spannbereich / clamping range: 2,0 - 20,0

Gewindebohrzange / tapping collet
 ET-1-32 M5-M12

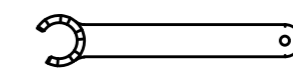

Spannzangenschlüssel für
 innenliegende Mutter
 Clamping wrench for
 internal collet
 232AX

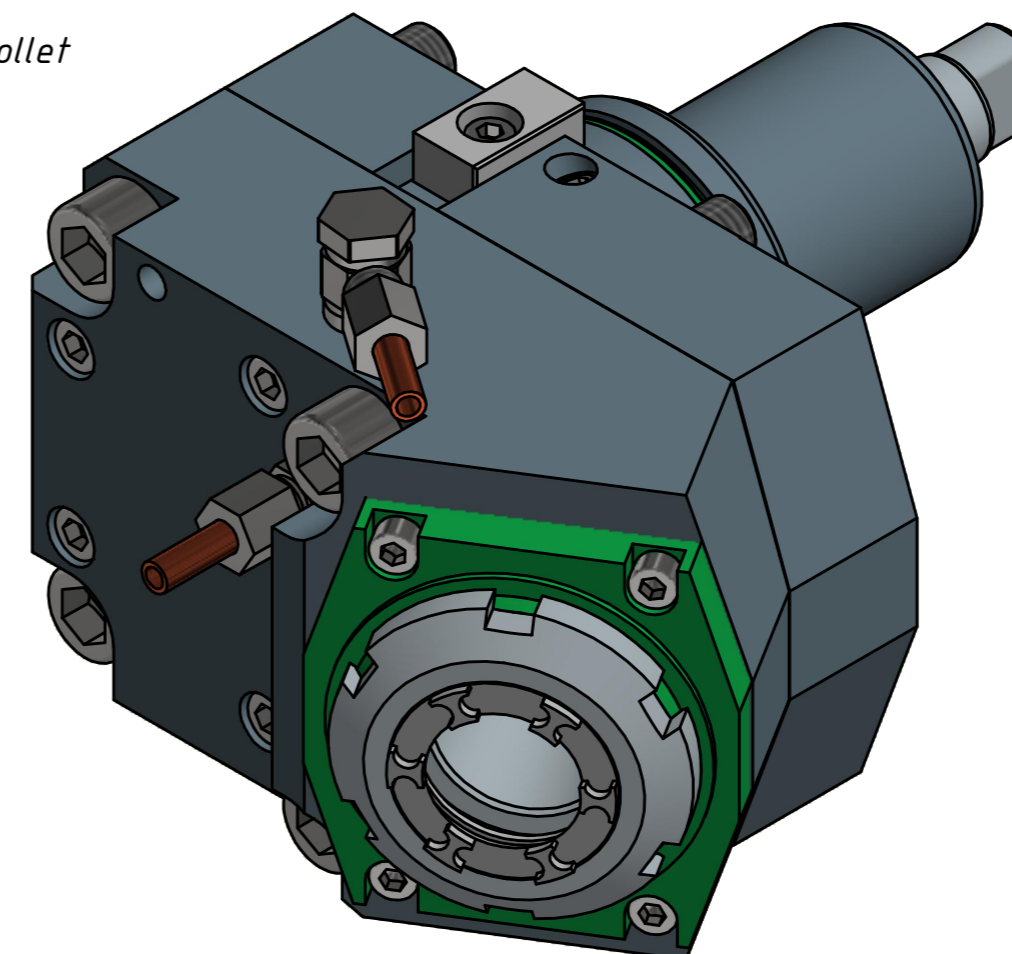
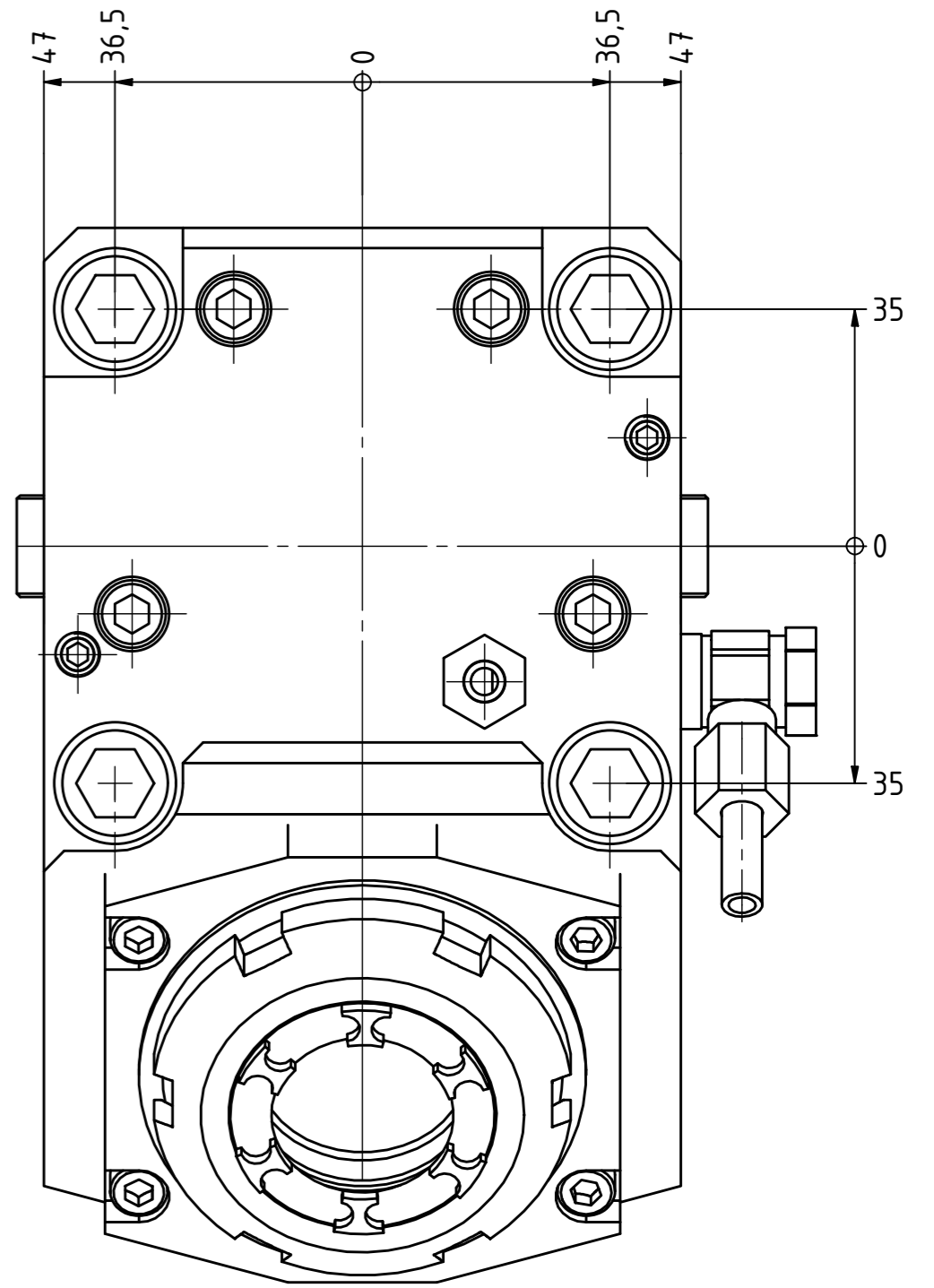
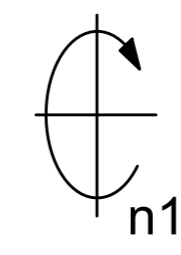
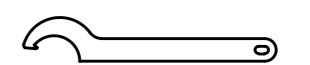

Hakenschlüssel
 mit Nase
 Hook wrench with
 nose end
 DIN1810 A 58x62

Copyright **EWS Tool Technologies**
 Weitergabe und Vervielfältigung dieser Unterlage,
 Verwertung und Mitteilung ihres Inhalts nicht
 gestattet, soweit nicht ausdrücklich zugestanden.
 Zuwiderhandlungen verpflichten zu Schadenersatz.

Bemerkung - Note

Technische Daten - technical data

Weight = 8.580 [kg]
 Torque max. (M1/M2) = 50 / 50 [Nm]
 Speed max. (n1/n2) = 6000 / 6000 [1/min]
 Gear ratio (i)=n1:n2 = 1:1

Benennung - Title

Radial Bohr und Fräskopf
Radial drilling and milling head



Nr. - No.
60.65321809N4IMTKW32

Technische Änderungen vorbehalten!
 Subject to technical modifications!
 IDENT: D-EWS-160692

REV: -/-
 MNR.
174691

