

Spannzange / collet ER32 DIN6499  
Spannbereich / clamping range: 2,0 - 20,0

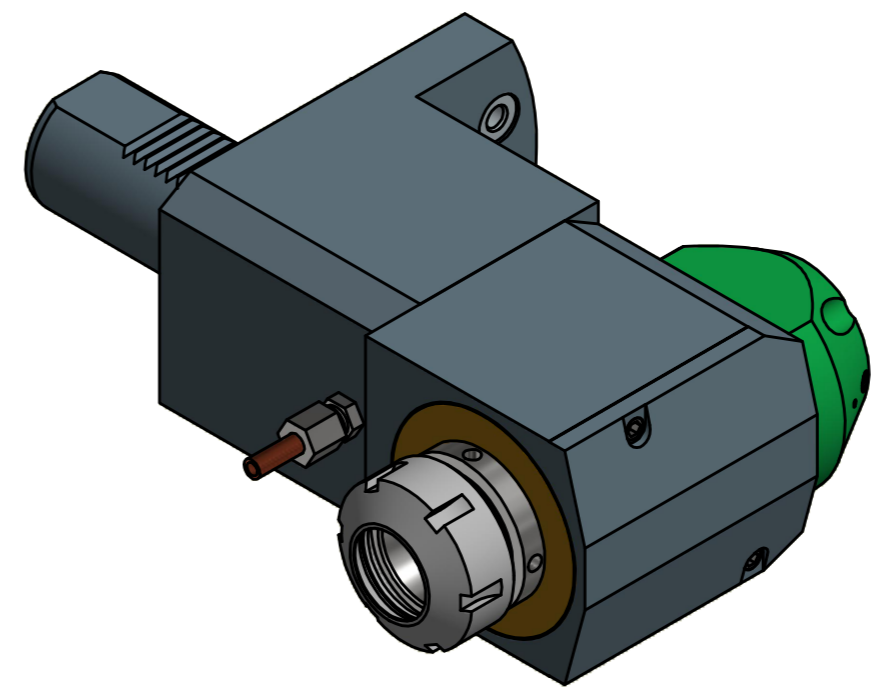

Hakenschlüssel  
mit Zapfen  
Hook wrench  
with fixed pin  
DIN1810 B 45x50

Spannzangenschlüssel  
Clamping wrench  
232

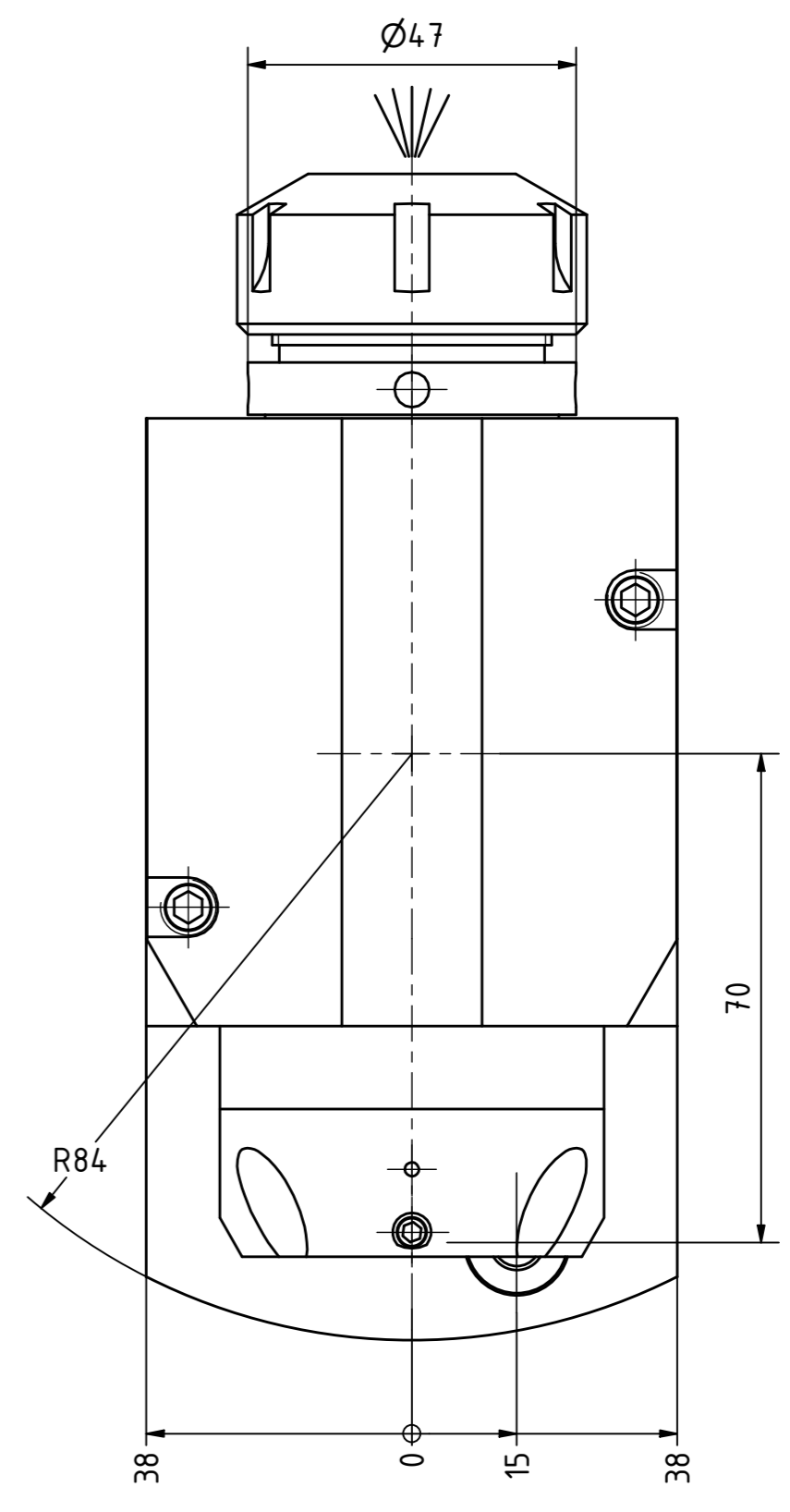
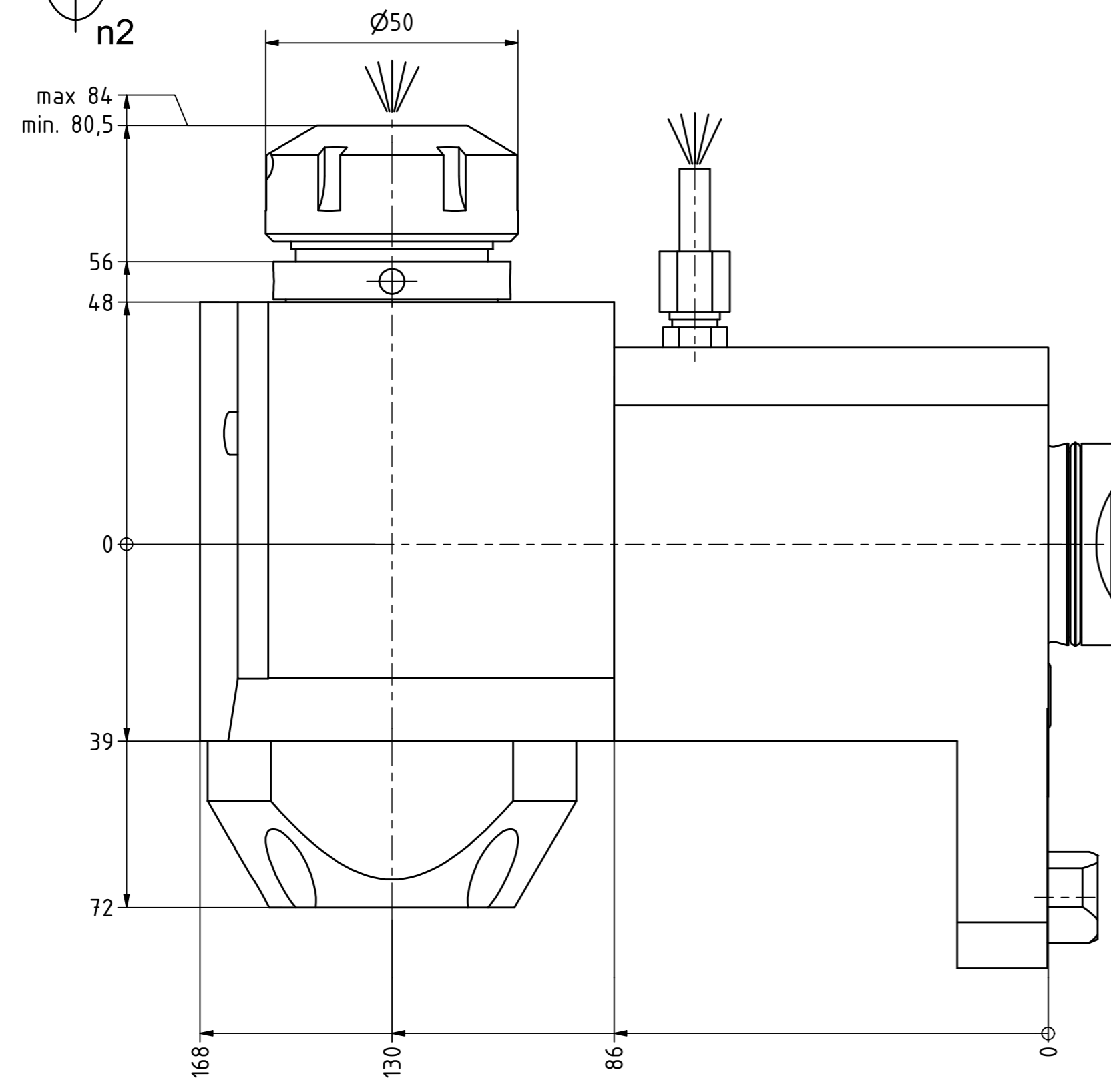
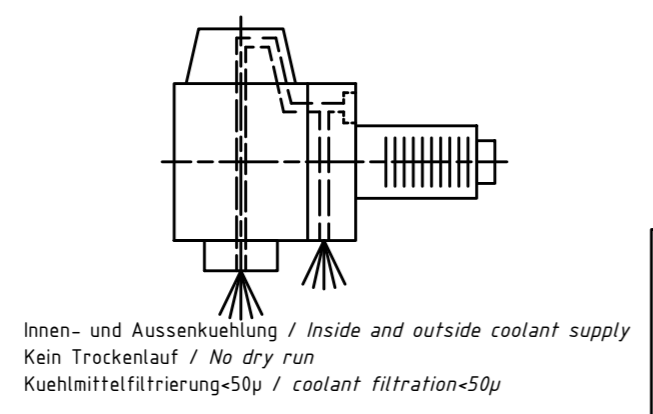

Bemerkung - Note Nicht ohne Kuehlmittel betreiben! Not for use without coolant-fluid!	Technische Daten - technical data
	Weight = 8.727 [kg]
	Torque max. (M1/M2) = 50 / 50 [Nm]
	Speed max. (n1/n2) = 6000 / 6000 [1/min]
	Pressure (pmax) = 70 [bar]

Benennung - Title  
**Radial Bohr und Fräskopf**  
**Radial drilling and milling head**

<b>EWS</b> <small>Tool Technologies</small> <small>EWS Weigle GmbH &amp; Co. KG          Maybachstr. 1          D-73066 Uhlingen          www.ews-tools.de</small>	Technische Aenderungen vorbehalten! Subject to technical modifications! IDENT: DEWS130235	Nr. - No. <b>60.4032MP620LIK</b>	MNR. <b>174860</b>	
	REV: -/A	<b>QR</b>		

Copyright EWS Tool Technologies  
Weitergabe und Vervielfaeltigung dieser Unterlage,  
Verwertung und Mitteilung ihres Inhalts nicht  
gestattet, soweit nicht ausdrecklich zugestanden.  
Zuwiderhandlungen verpflichten zu Schadenersatz.