

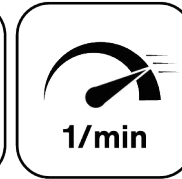

Ceramic Seal



Highspeed



Tech Details

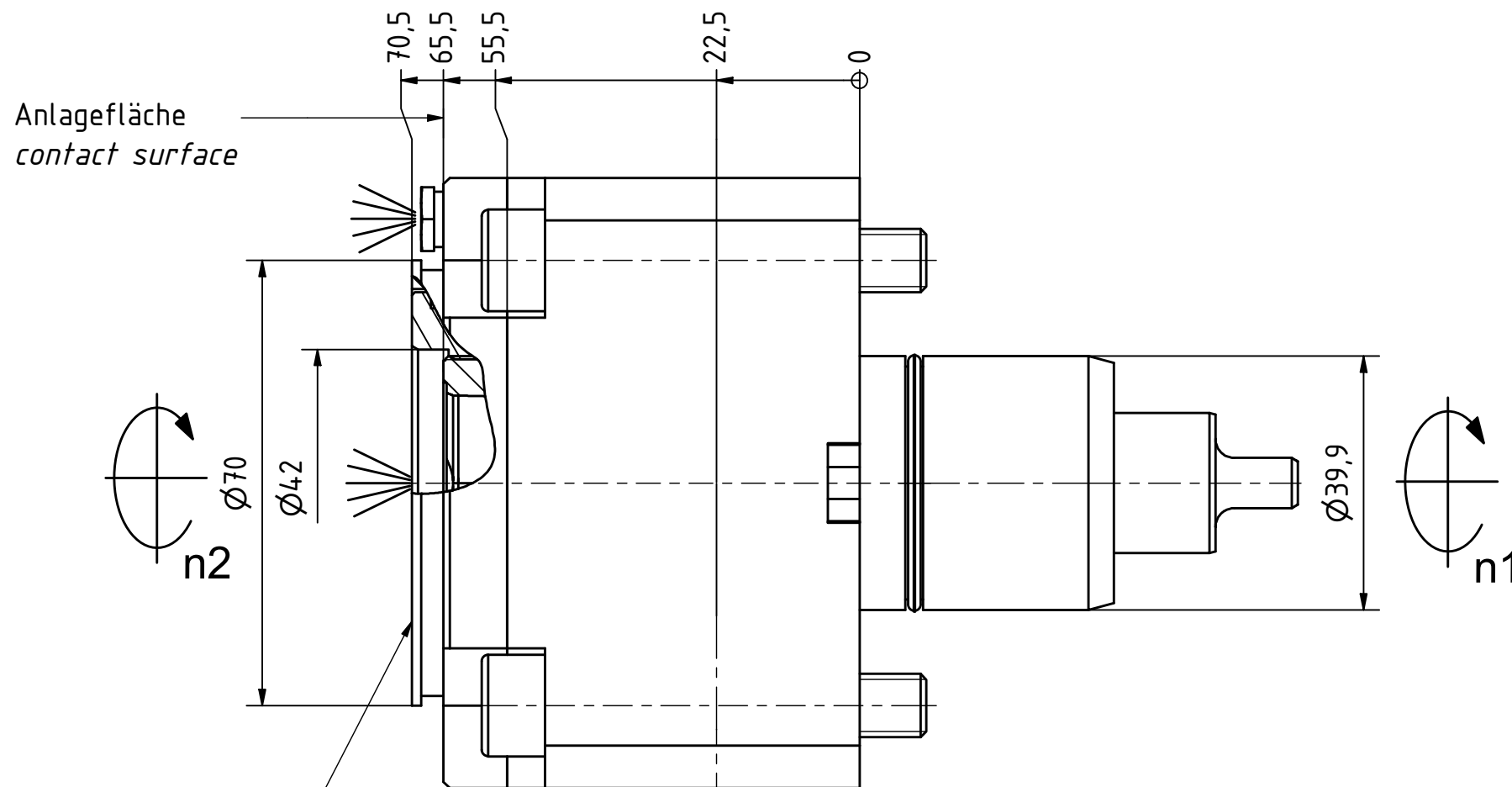

Anlagefläche
contact surface

Capto C4-Aufnahme
Capto C4-Adaptor

Anzugsdrehmoment 45Nm
Clamping torque 45Nm

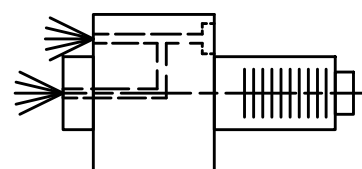
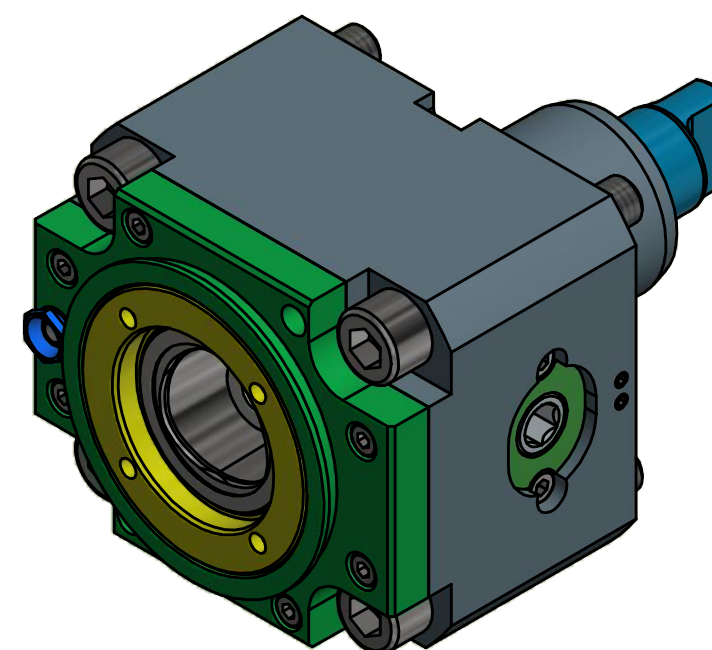
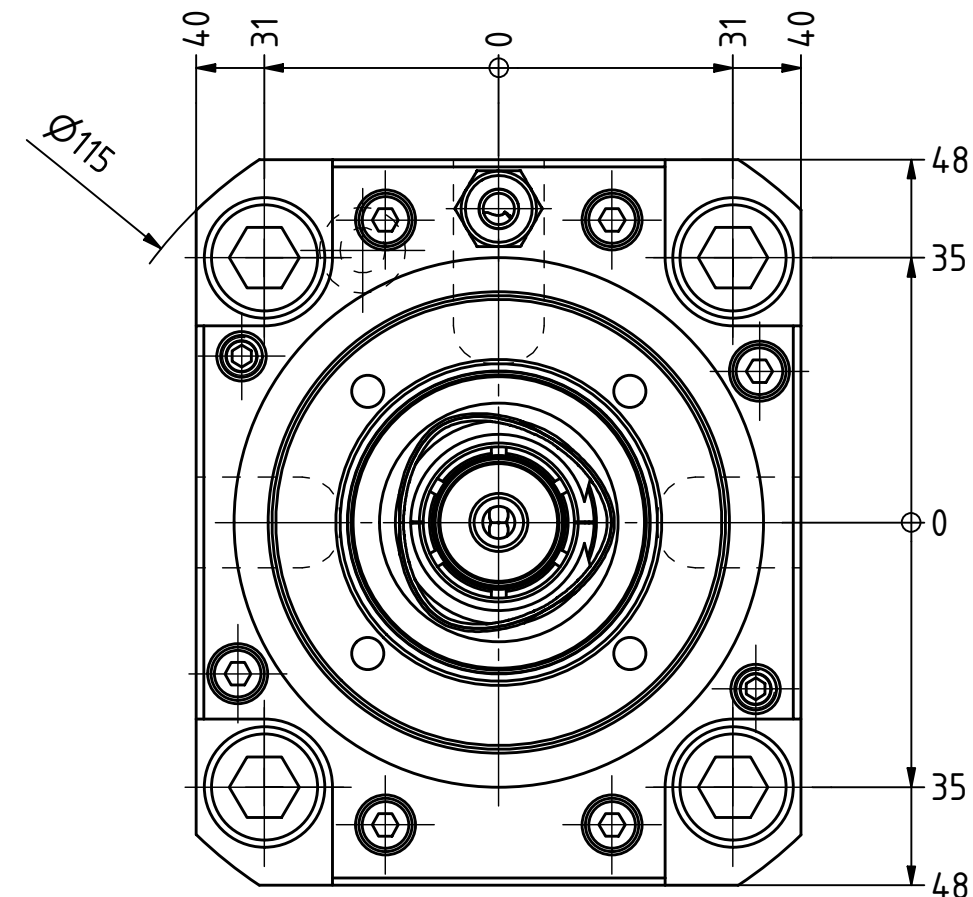

Innen- und Aussenkuehlung / Inside and outside coolant supply
Kuehlmittelfiltrierung 50μ / coolant filtration 50μ

Copyright **EWS Tool Technologies**

Weitergabe und Vervielfaeltigung dieser Unterlage, Verwertung und Mitteilung ihres Inhalts nicht gestattet, soweit nicht ausdrecklich zugestanden. Zuwiderhandlungen verpflichten zu Schadenersatz.

Bemerkung - Note
Für Trockenlauf geeignet!
Use without coolant fluid allowed!

Technische Daten - technical data	
Weight	= 3,981 [kg]
Torque max. (M1/M2)	= 32 / 32 [Nm]
Speed max. (n1/n2)	= 12000 / 12000 [1/min]
Gear ratio (i)=n1:n2	= 1:1
Pressure (pmax)	= 70 [bar]

Benennung - Title
Axial Bohr und Fräskopf
Axial drilling and milling head



Nr. - No.
40.40C4NZIKCHSD12

Technische Aenderungen vorbehalten!
Subject to technical modifications!

IDENT: DEWS106500



REV: -/A

MNR.
199792

