

Spannzange / collet ER25 DIN6499
 Spannbereich / clamping range: 1,0 - 16,0

Gewindebohrzange / tapping collet
 ET-1-25 M3-M12

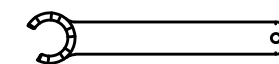

Spannzangenschlüssel für
 innenliegende Mutter
*Clamping wrench for
 internal collet*
 225AX

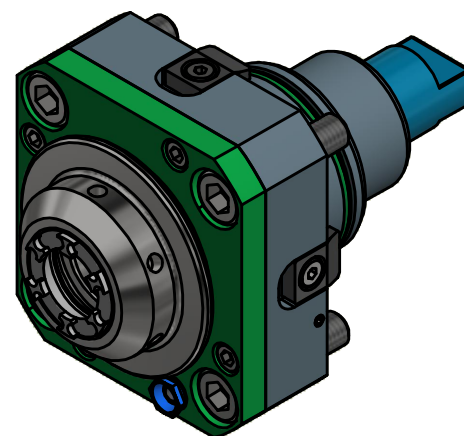
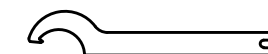

Hakenschlüssel
 mit Nase
*Hook wrench with
 nose end*
 DIN1810 A 68x75

Copyright **EWS Tool Technologies**
 Weitergabe und Vervielfältigung dieser Unterlage,
 Verwertung und Mitteilung ihres Inhalts nicht
 gestattet, soweit nicht ausdrücklich zugestanden.
 Zuwiderhandlungen verpflichten zu Schadenersatz.

Bemerkung - Note

Technische Daten - technical data

Benennung - Title

Weight = 2.676 [kg]
 Torque max. (M1/M2) = 50 / 50 [Nm]
 Speed max. (n1/n2) = 6000 / 6000 [1/min]
 Gear ratio (i)=n1:n2 = 1:1

Axial Bohr und Fräskopf
Axial drilling and milling head



Nr. - No.
40.5525VLHP2EKIM

Technische Änderungen vorbehalten!
 Subject to technical modifications!

IDENT: DEWS039597



REV: -/B

MNR.

199231

