

Doppelverzahnung Lizenz Traub
double tooth system licence Traub

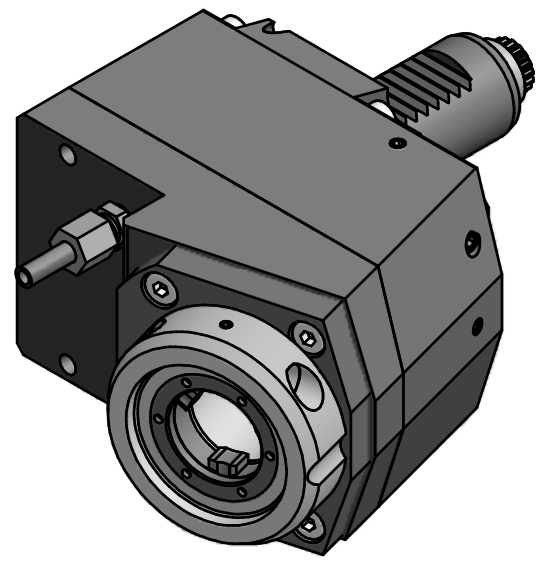

Copyright **EWS Tool Technologies**
Weitergabe und Vervielfaeltigung dieser Unterlage,
Verwertung und Mitteilung ihres Inhalts nicht
gestattet, soweit nicht ausdruuecklich zugestanden.
Zuwaiderhandlungen verpflichten zu Schadenersatz.

<p>Bemerkung - Note</p>	<p>Technische Daten - technical data</p> <p>Weight = 6.005 [kg] Torque max. (M1/M2) = 25 / 25 [Nm] Speed max. (n1/n2) = 8000 / 8000 [1/min] Gear ratio (i)=n1:n2 = 1:1</p>	<p>Benennung - Title</p> <p>Radial Bohr und Fräskopf <i>Radial drilling and milling head</i></p>	<p>EWS Tool Technologies</p> <p>EWS Weigle GmbH & Co. KG Maybachstr. 1 D-73066 Uthingen www.ews-tools.de</p>	<p>Technische Aenderungen vorbehalten! Subject to technical modifications!</p> <p>IDENT: D-EWS-201062</p>	<p>REV: A/-</p> <p>MNR.</p> <p>191978</p>	<p>QR</p>
		<p>Nr. - No.</p> <p>60.30VX3CTXRLTFRTKW15</p>				