

Sondermaschine!!!
 Bitte eine Kollisionsprüfung durchführen.
Special machine design!!!
 Please make an interferences check.

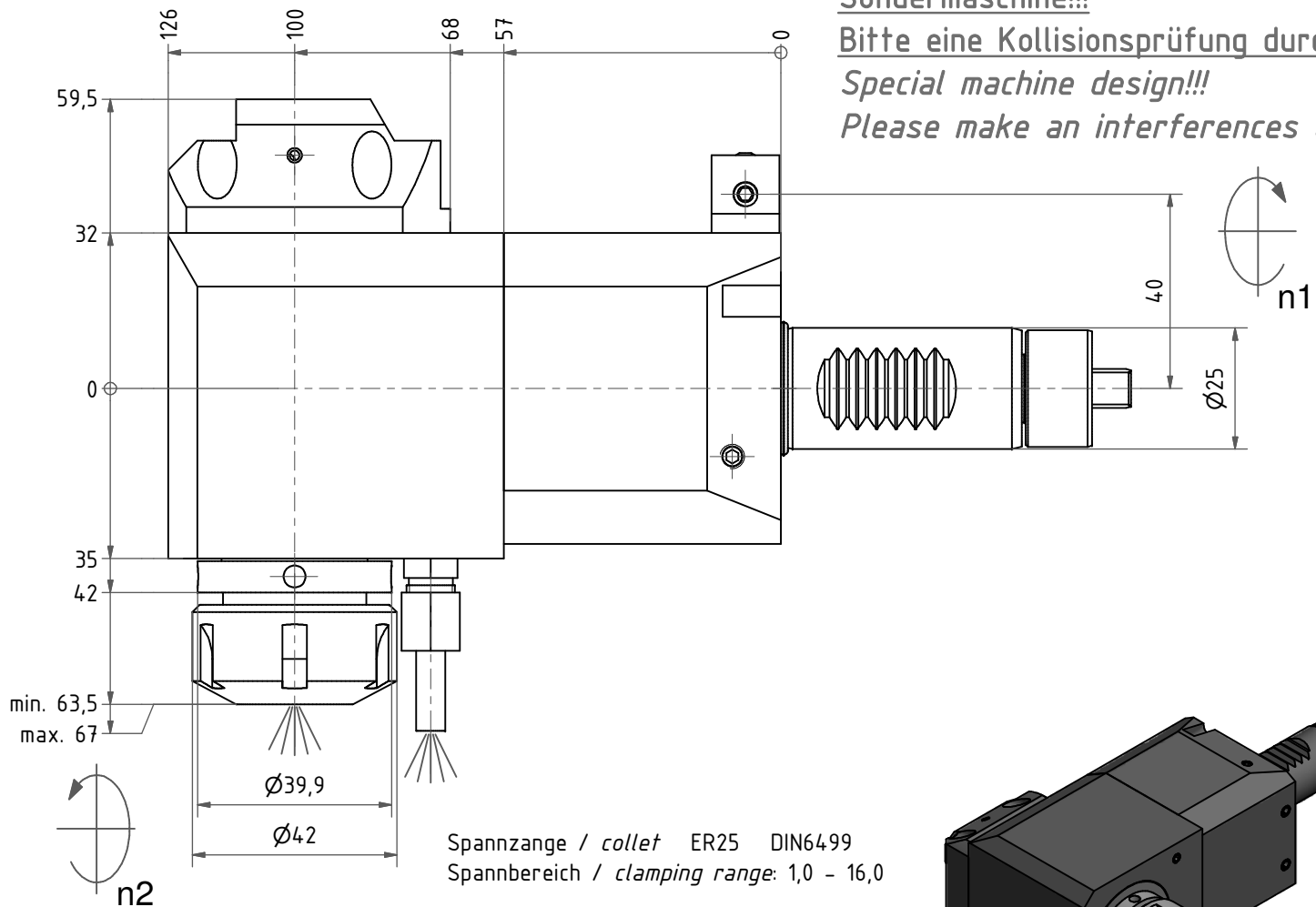

Spannzange / collet ER25 DIN6499
 Spannbereich / clamping range: 1,0 - 16,0

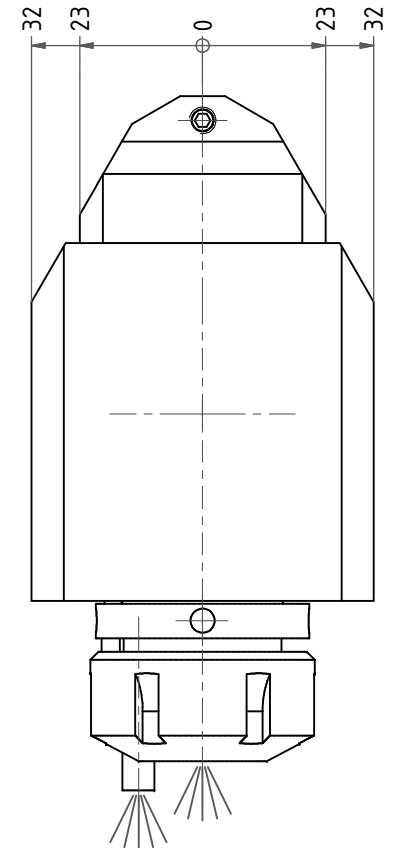
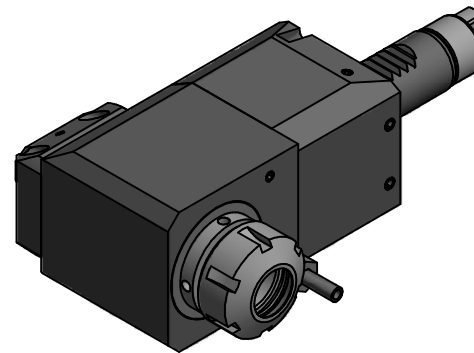

Hakenschlüssel
 mit Zapfen
 Hook wrench
 with fixed pin
 DIN1810 B 40x42

Spannzangenschlüssel
 Clamping wrench
 225

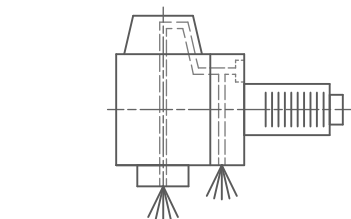

Innen- und Aussenkuehlung / Inside and outside coolant supply
 Kein Trockenlauf / No dry run
 Kuehlmittelfiltrierung=50µ / coolant filtration=50µ

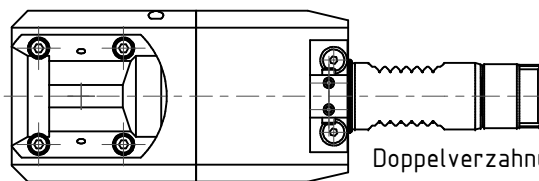

Doppelverzahnung Lizenz Traub
 double tooth system licence Traub

Copyright **EWS Tool Technologies**
 Weitergabe und Vervielfaeltigung dieser Unterlage,
 Verwertung und Mitteilung ihres Inhalts nicht
 gestattet, soweit nicht ausdruercklich zugestanden.
 Zuwiderhandlungen verpflichten zu Schadenersatz.

Bemerkung - Note
 Nicht ohne Kuehlmittel betreiben!
 Not for use without coolant-fluid!

Technische Daten - technical data
 Weight = 4.030 [kg]
 Torque max. (M1/M2) = 25 / 25 [Nm]
 Speed max. (n1/n2) = 8000 / 8000 [1/min]
 Gear ratio (i)=n1:n2 = 1:1
 Pressure (pmax) = 70 [bar]

Benennung - Title
Radial Bohr und Fräskopf
Radial drilling and milling head



Nr. - No.
60.2525TDRLIKX100

Technische Aenderungen vorbehalten!
 Subject to technical modifications!
 IDENT: DEWS023775

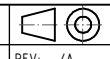

REV: -/A

MNR.
167550

