

Spannzange / collet ER25 DIN6499  
 Spannungsbereich / clamping range: 1,0 - 16,0

Gewindebohrzange / tapping collet  
 ET-1-25 M3-M10

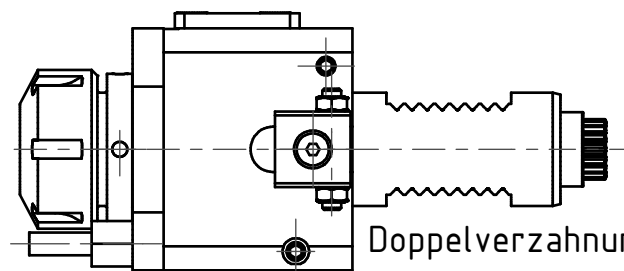

Doppelverzahnung Lizenz Traub  
 double tooth system licence Traub

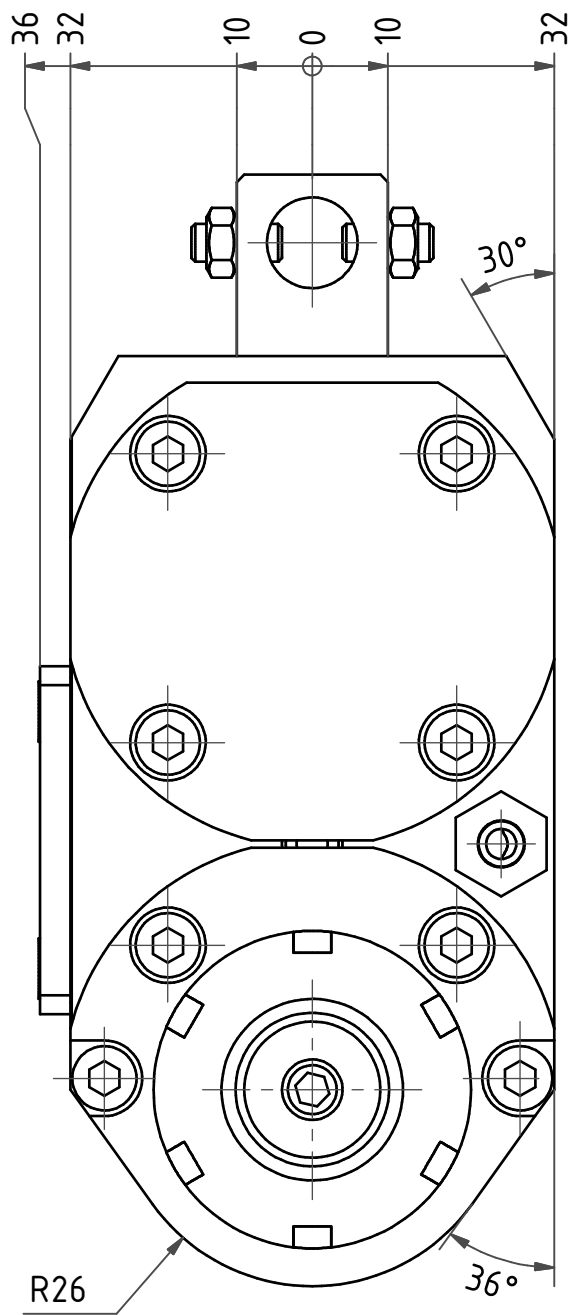
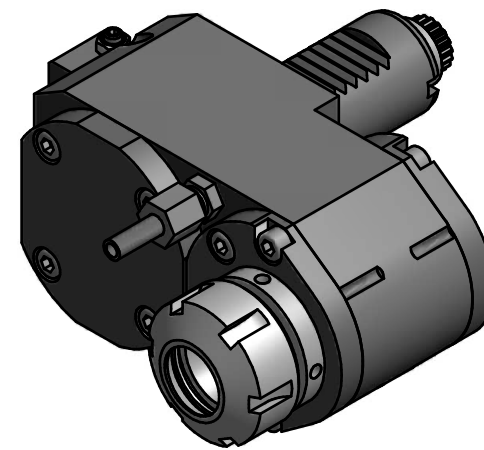

Spannzangenschlüssel  
 Clamping wrench  
 225

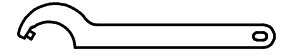

Hakenschlüssel  
 mit Zapfen  
 Hook wrench  
 with fixed pin  
 DIN1810 B 40x42

Copyright **EWS Tool Technologies**  
 Weitergabe und Vervielfältigung dieser Unterlage,  
 Verwertung und Mitteilung ihres Inhalts nicht  
 gestattet, soweit nicht ausdrücklich zugestanden.  
 Zuwiderhandlungen verpflichten zu Schadenersatz.

Bemerkung - Note	Technische Daten - technical data M1 / M2 = 25 / 25 Nm n1 / n2 = 8000 / 8000 1/min i (N1:N2) = 1:1	Benennung - Title <b>Axial Bohr u. Fräskopf achsversetzt</b> <b>Ax. drill. and mill. head offset</b>	<table border="1"> <tr> <td>name</td> <td>date</td> </tr> <tr> <td>Lukjanow</td> <td>07.12.2011</td> </tr> </table>	name	date	Lukjanow	07.12.2011	Technische Aenderungen vorbehalten! Subject to technical modifications! Nr. <b>50.3025CTXRL-S01</b>	
name	date								
Lukjanow	07.12.2011								
			EWS Weigte GmbH & Co. KG Maybachstr. 1 D-73066 Uhlingen Tel. +49(0)7161/93040-100	MNR: 1574.70 IDENT: D-EWS-112700 A Blatt - page 1 (1)					