

6 | 5 | 4 | 3 | 2 | 1

D
C
B
A

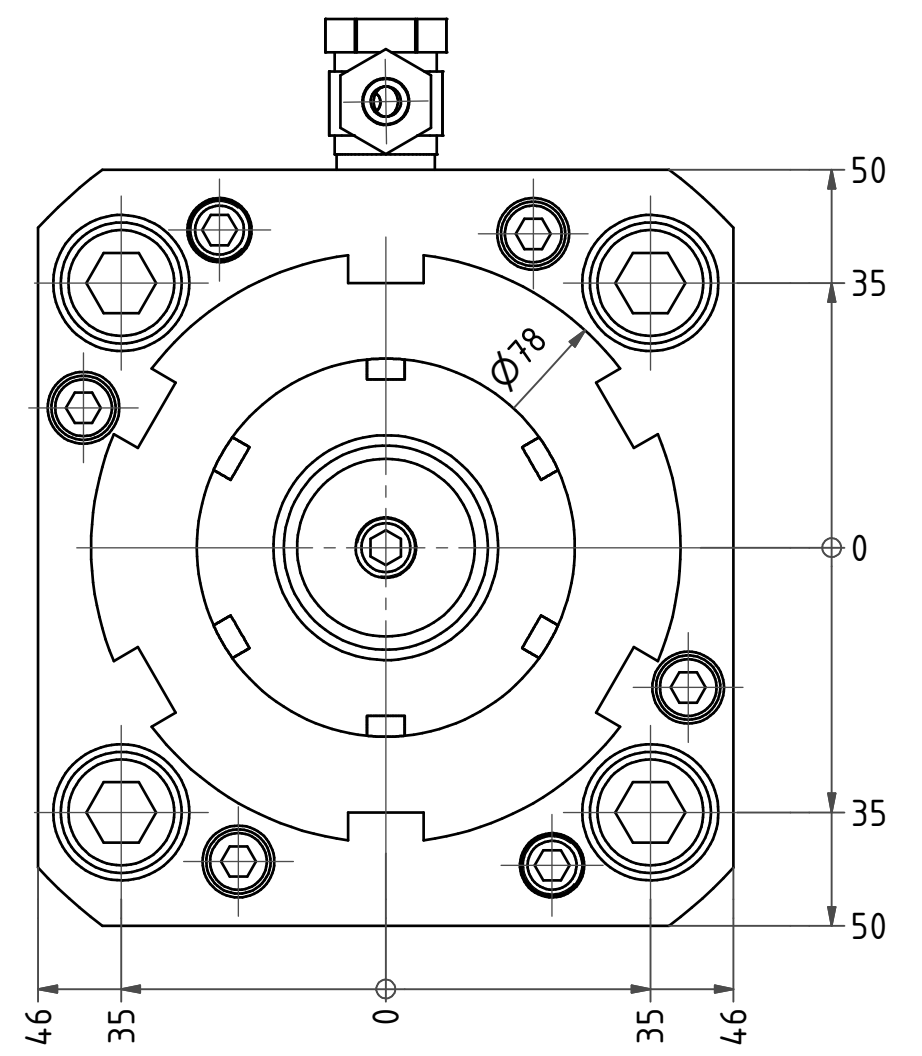
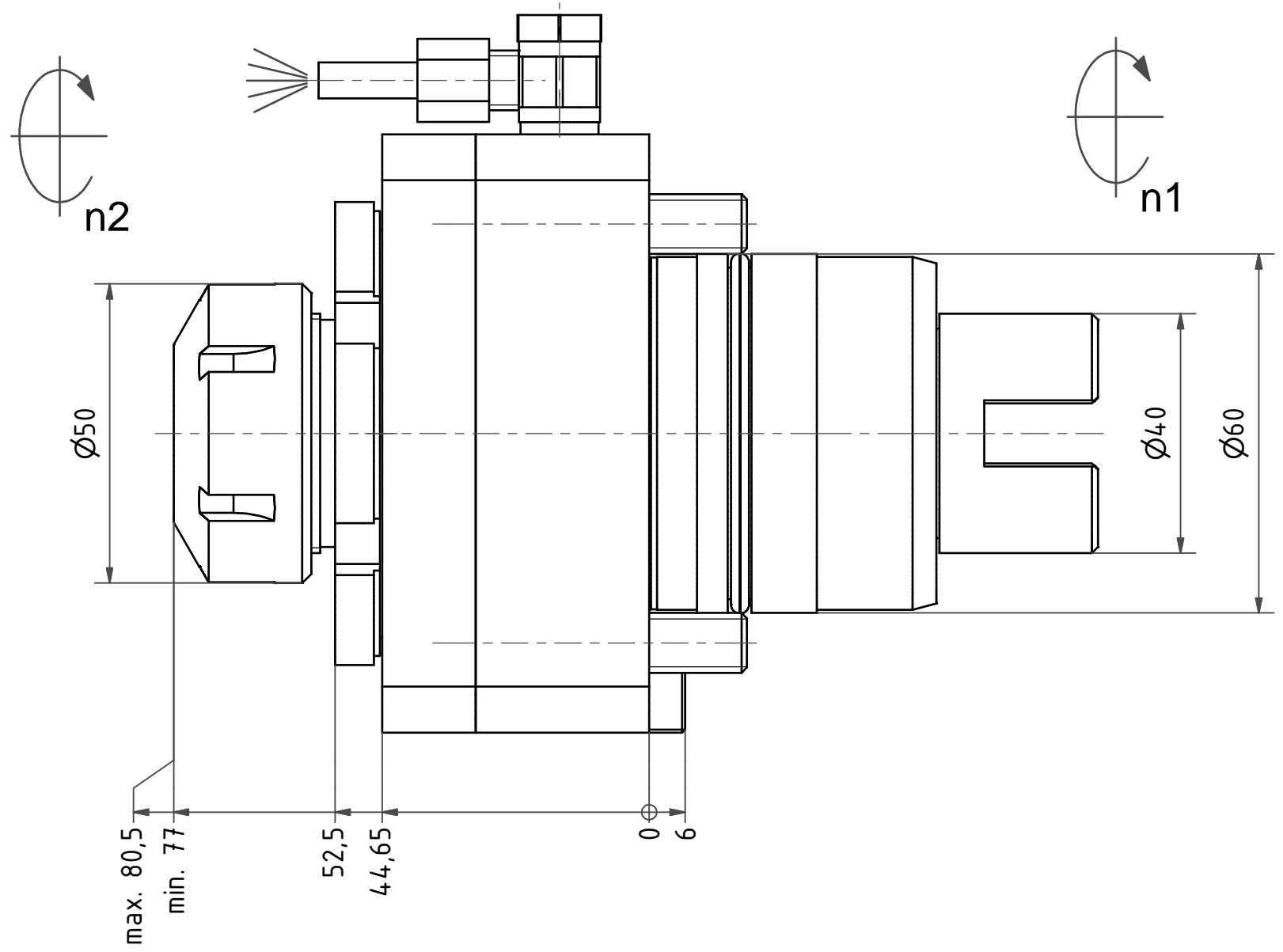

Spannzange / collet ER32 DIN6499
 Spannungsbereich / clamping range: 2,0 - 20,0

Gewindebohrzange / tapping collet
 ET-1-32 M5-M12

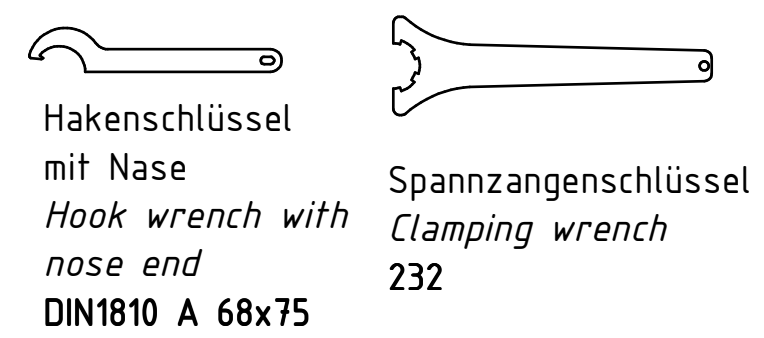
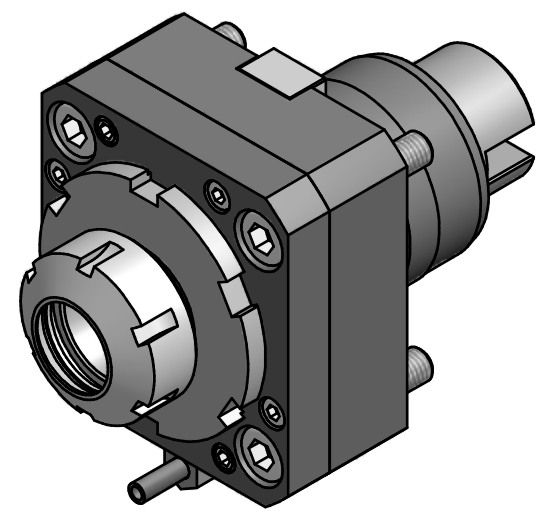

Copyright **EWS Tool Technologies**
 Weitergabe und Vervielfältigung dieser Unterlage,
 Verwertung und Mitteilung ihres Inhalts nicht
 gestattet, soweit nicht ausdrücklich zugestanden.
 Zuwiderhandlungen verpflichten zu Schadenersatz.

Bemerkung - Note	Technische Daten - technical data M1 / M2 = 50 / 50 Nm n1 / n2 = 6000 / 6000 1/min i (N1:N2) = 1:1	Benennung - Title Axial Bohr und Fräskopf <i>Axial drilling and milling head</i>	name	date	Technische Änderungen vorbehalten! Subject to technical modifications!	
			drawing	Schmid		
			EWS Weigete GmbH & Co. KG Maybachstr. 1 D-73066 Uhingen Tel. +49(0)7161/93040-100		Nr. 40.6032EX508BMT	DIN A3
			MNR: 174237		IDENT: D-EWS-182099 -	Blatt - page 1 (1)

6 | 5 | 4 | 3 | 2 | 1