

Spannzange / collet ER40 DIN6499  
 Spannbereich / clamping range: 3,0 - 26,0

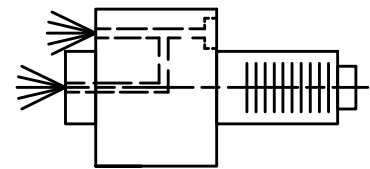

Innen- und Aussenkuehlung / Inside and outside coolant supply  
 Kein Trockenlauf / No dry run  
 Kuehlmittelfiltrierung <math>< 50\mu</math> / coolant filtration <math>< 50\mu</math>

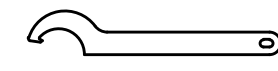
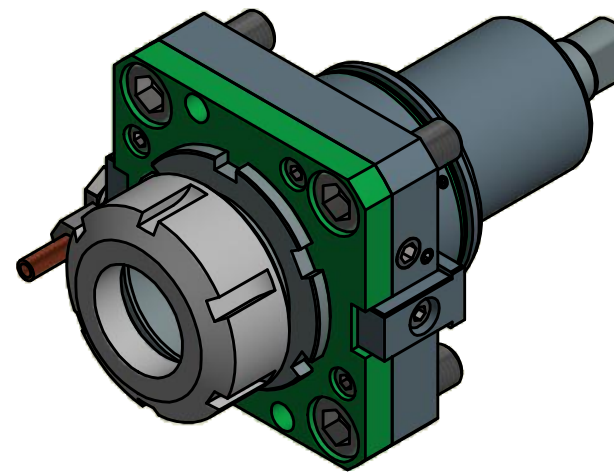

Hakenschlüssel  
 mit Nase  
 Hook wrench with  
 nose end  
 DIN1810 A 68x75

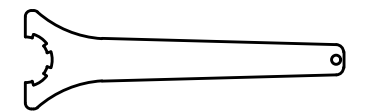

Spannzangenschlüssel  
 Clamping wrench  
 240

Copyright **EWS Tool Technologies**  
 Weitergabe und Vervielfaeltigung dieser Unterlage,  
 Verwertung und Mitteilung ihres Inhalts nicht  
 gestattet, soweit nicht ausdrecklich zugestanden.  
 Zuwiderhandlungen verpflichten zu Schadenersatz.

Bemerkung - Note  
 Nicht ohne Kuehlmittel betreiben!  
 Not for use without coolant-fluid!

Technische Daten - technical data  
 Weight = 3,478 [kg]  
 Torque max. (M1/M2) = 50 / 50 [Nm]  
 Speed max. (n1/n2) = 6000 / 6000 [1/min]  
 Gear ratio (i)=n1:n2 = 1:1  
 Pressure (pmax) = 25 [bar]

Benennung - Title  
 Axial Bohr und Fräskopf  
 Axial drilling and milling head



Nr. - No.  
 40.65401809DW02IK

Technische Aenderungen vorbehalten!  
 Subject to technical modifications!  
 IDENT: DEWS095164

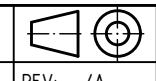

REV: -/A  
 MNR.  
 198500

