

Spannzange / Collet ER16 DIN6499  
 Spannungsbereich / Clamping range: 1,0 - 10,0

Gewindebohrzange / Tapping Collet  
 ET-1-16 M1-M6

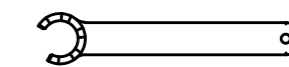

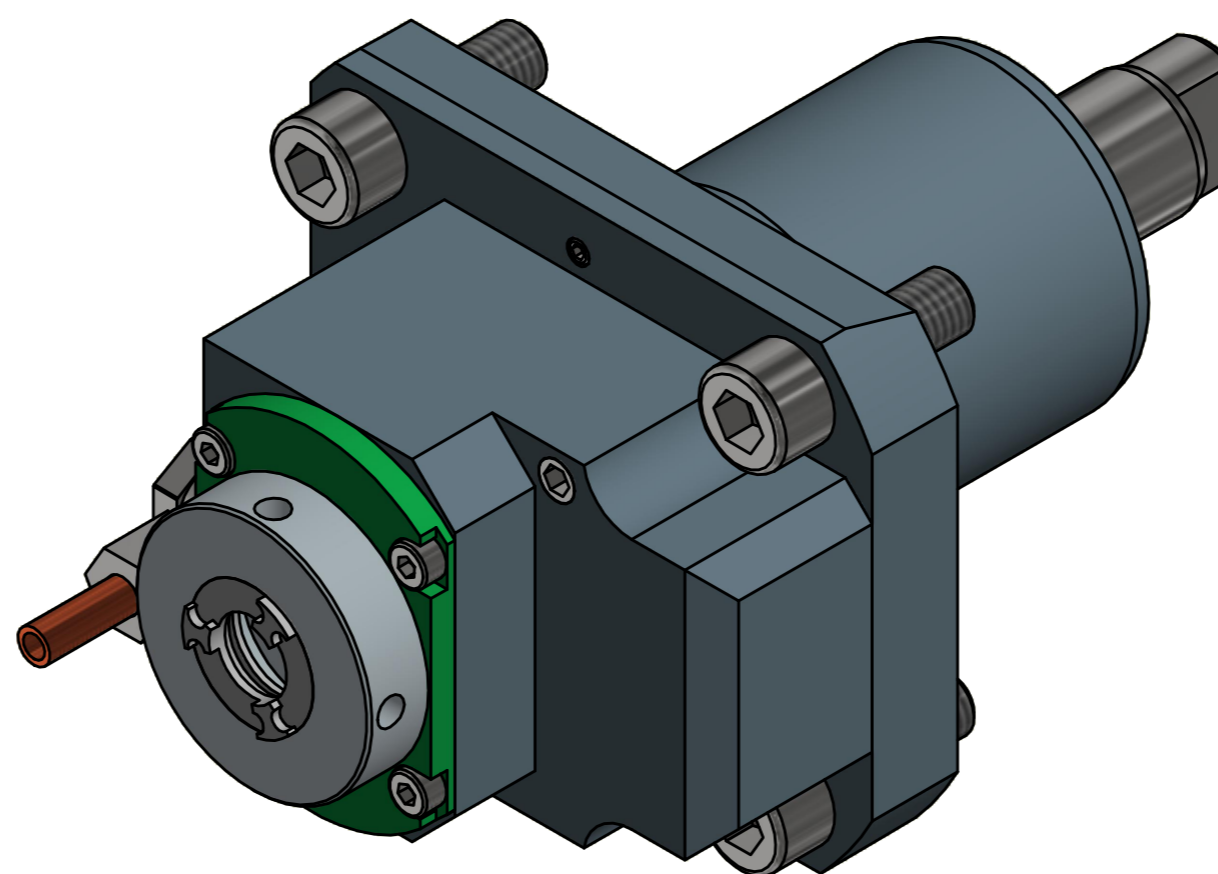
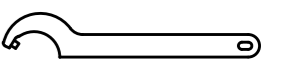

Spannzangenschlüssel für  
 innenliegende Mutter  
 Clamping wrench for  
 internal collet  
 216AX

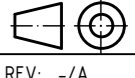

Hakenschlüssel  
 mit Zapfen  
 Hook wrench  
 with fixed pin  
 DIN1810 B 45x50

Copyright **EWS Tool Technologies**  
 Weitergabe und Vervielfältigung dieser Unterlage,  
 Verwertung und Mitteilung ihres Inhalts nicht  
 gestattet, soweit nicht ausdrücklich zugestanden.  
 Zuwiderhandlungen verpflichten zu Schadenersatz.

Bemerkung - Note	Technische Daten - technical data Weight = 3,492 [kg] Torque max. (M1/M2) = 15 / 5 [Nm] Speed max. (n1/n2) = 6000 / 18000 [1/min] Gear ratio (i)=n1:n2 = 1:3	Benennung - Title <b>Axial Bohr und Fräskopf</b> <b>Axial drilling and milling head</b>	 <b>EWS</b> Weigle GmbH & Co. KG Maybachstr. 1 D-73066 Ulm/ingen www.ews-tools.de	Technische Änderungen vorbehalten! Subject to technical modifications! IDENT: D-EWS-218259 Nr. - No. <b>4.0.55.4.16LT2000V16113GLIM</b>	 MNR <b>198028</b>	
------------------	--	---	---	---	---	---