

Spannzange / Collet ER16 DIN6499
 Spannbereich / Clamping range: 1,0 - 10,0

Gewindebohrzange / Tapping Collet
 ET-1-16 M4,5-M12

Gewindeschneideinheit selbst reversierend (M4,5 - M12)
 Self-reversing tapping unit (M4,5 - M12)

Doppelverzahnung Lizenz Traub
 double tooth system licence Traub

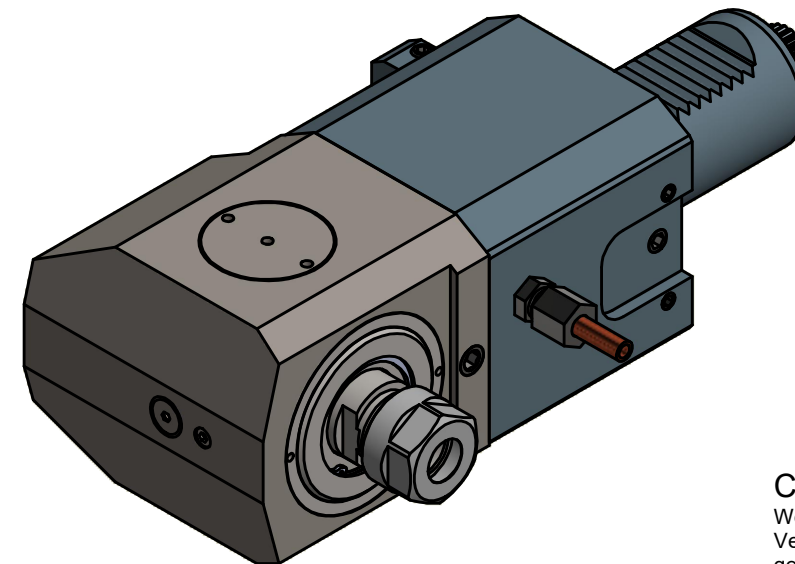
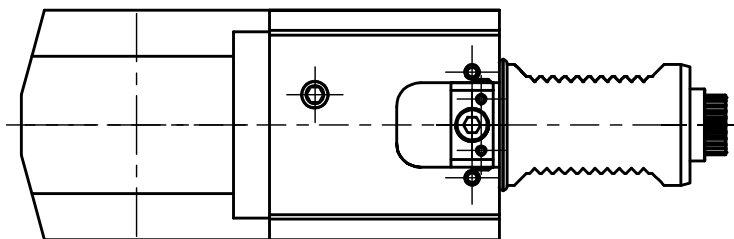

Copyright **EWS Tool Technologies**
 Weitergabe und Vervielfaeltigung dieser Unterlage,
 Verwertung und Mitteilung ihres Inhalts nicht
 gestattet, soweit nicht ausdrecklich zugestanden.
 Zuwiderhandlungen verpflichten zu Schadenersatz.

Bemerkung - Note	Technische Daten - technical data Weight = 7.006 [kg] Torque max. (M1/M2) = 23,3 / 35 [Nm] Speed max. (n1/n2) = 3300 / 2200 [1/min] Gear ratio (i)=n1:n2 = 1,5:1	Benennung - Title Radial Gewindebohrkopf Radial Tapping head	 EWS Weigele GmbH & Co. KG Maybachstr. 1 D-73066 Utingen www.ews-tools.de	Technische Aenderungen vorbehalten! Subject to technical modifications! IDENT: DEWS127505	 REV: -/C MNR. 190948	
			Nr. - No. 61.4016TMLCTXRLI151			