

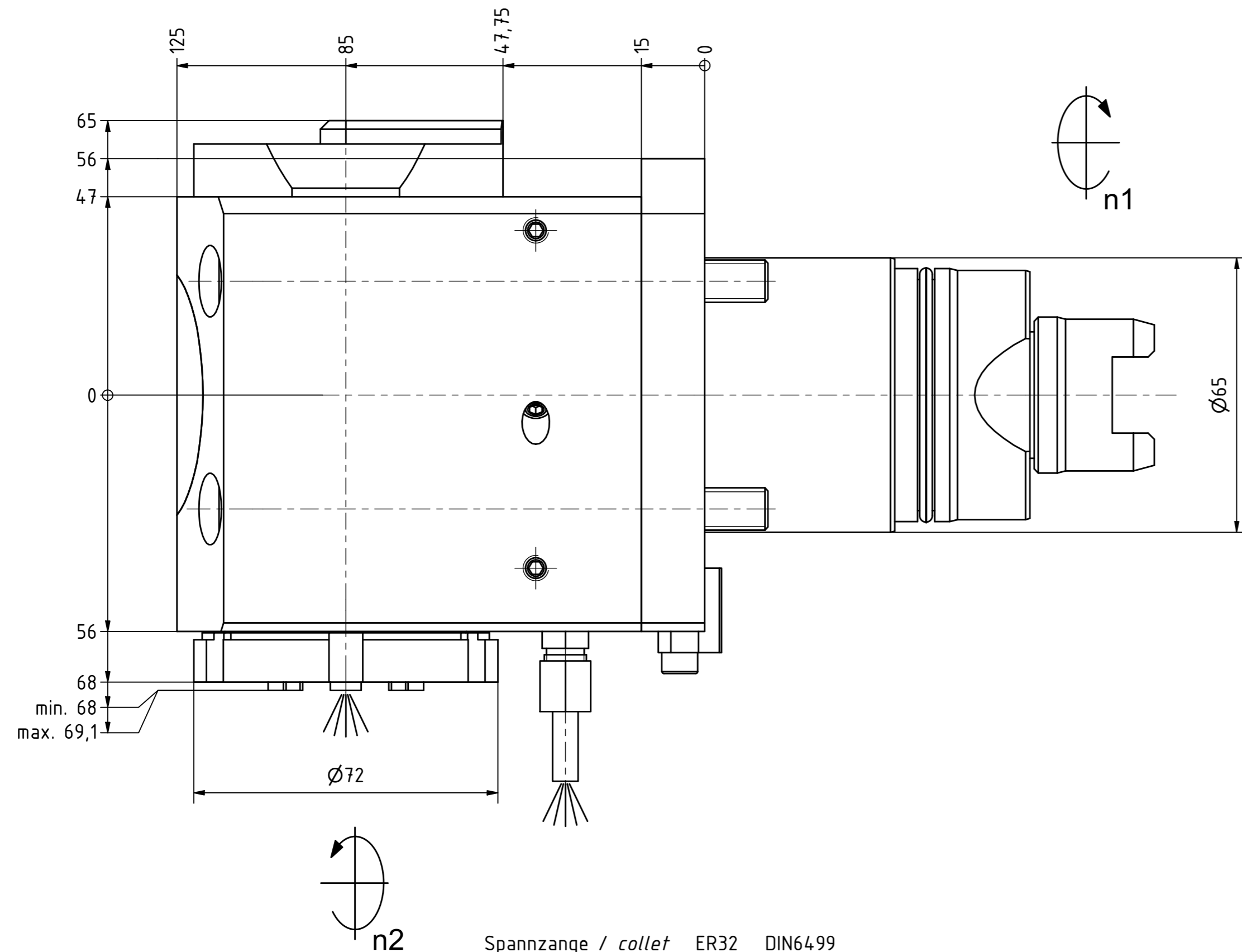

Ceramic Seal



Tech Details



Spannzange / collet ER32 DIN6499  
 Spannbereich / clamping range: 2,0 - 20,0

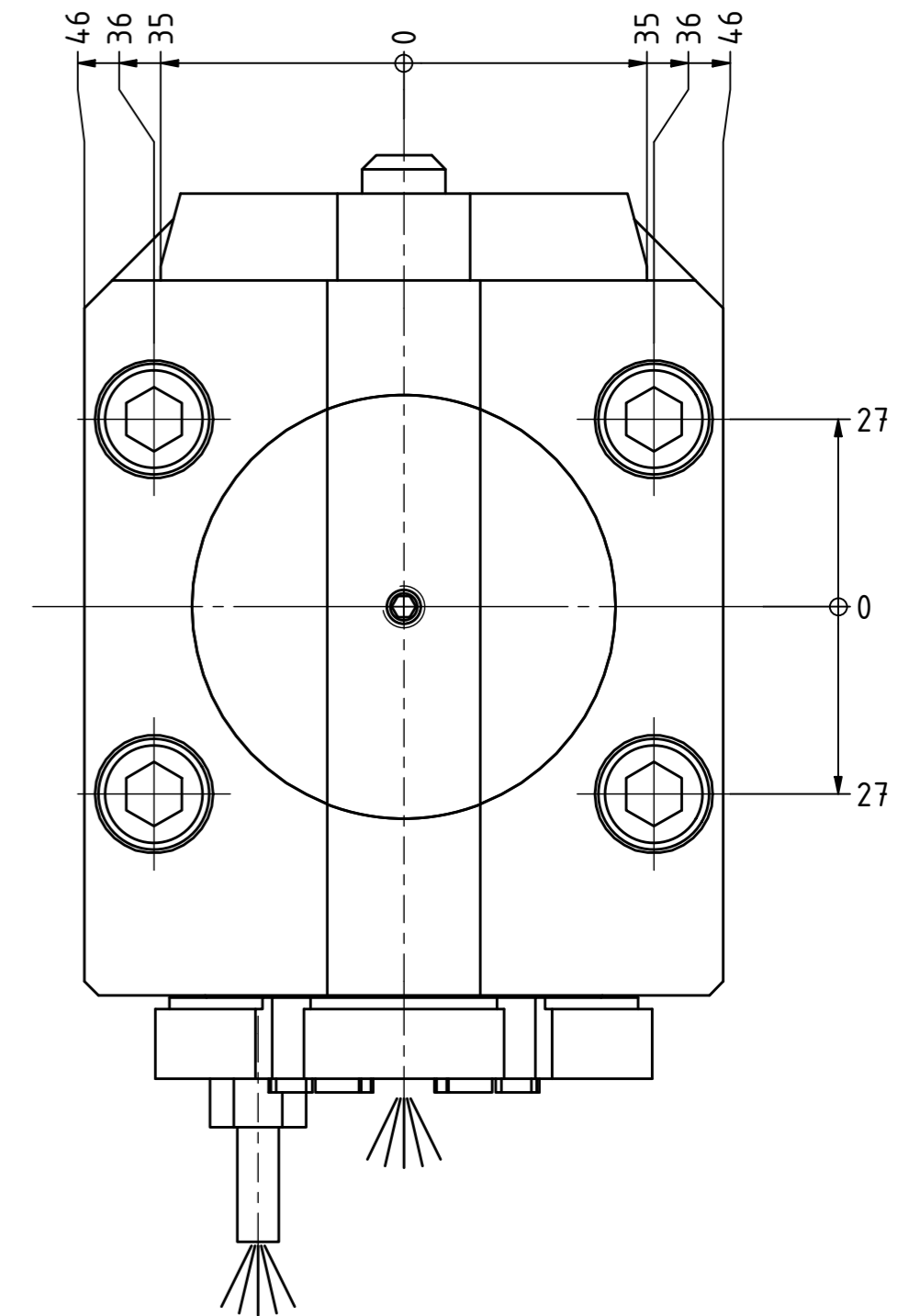

Z (1:1)

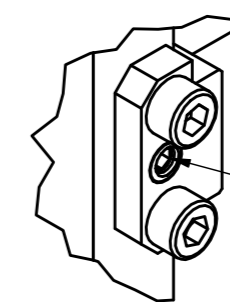

Ausrichtklotz ist über ein Exzenter einstellbar.  
 The block is adjustable via eccentric.

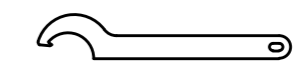

Hakenschlüssel mit Nase  
 Hook wrench with nose end  
 DIN1810 A 68x75

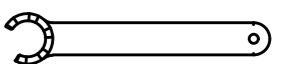

Spannzangenschlüssel für innenliegende Mutter  
 Clamping wrench for internal collet  
 232AX

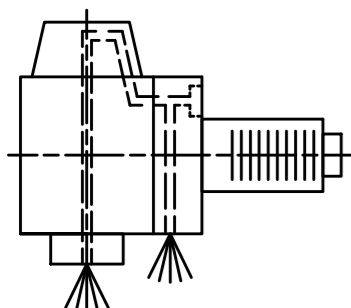
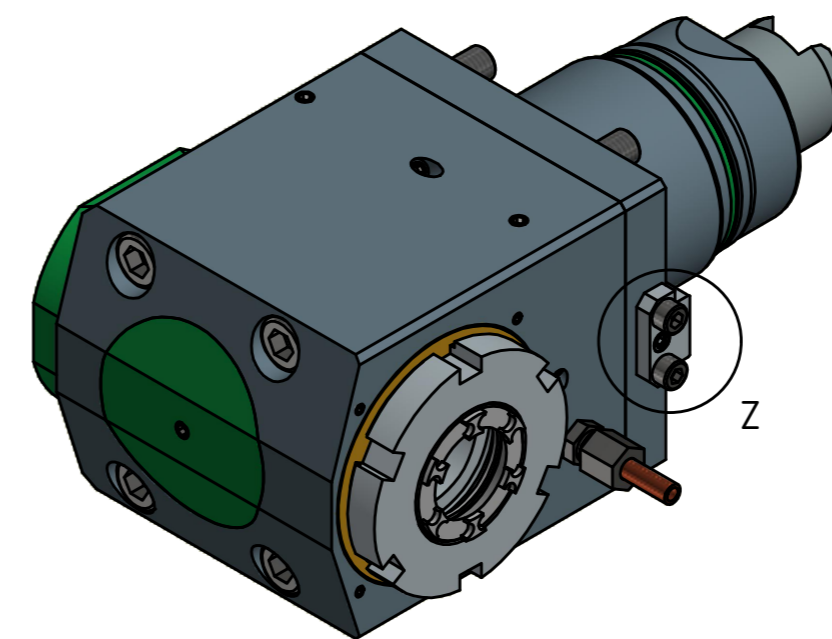

Innen- und Aussenkühlung / Inside and outside coolant supply  
 Kuehlmittelfiltrierung-50µ / coolant filtration-50µ

Copyright EWS Tool Technologies  
 Weitergabe und Vervielfältigung dieser Unterlage, Verwertung und Mitteilung ihres Inhalts nicht gestattet, soweit nicht ausdrücklich zugestanden. Zuwiderhandlungen verpflichten zu Schadenersatz.

Bemerkung - Note  
 Für Trockenlauf geeignet!  
 Use without coolant fluid allowed!

Technische Daten - technical data  
 Weight = 9.991 [kg]  
 Torque max. (M1/M2) = 50 / 50 [Nm]  
 Speed max. (n1/n2) = 6000 / 6000 [1/min]  
 Gear ratio (i)=n1:n2 = 1:1  
 Pressure (pmax) = 70 [bar]

Benennung - Title  
 Radial Bohr und Fräskopf  
 Radial drilling and milling head

EWS Tool Technologies  
 EWS Weigle GmbH & Co. KG  
 Maybachstr. 1  
 D-73066 Ulm/ingen  
 www.ews-tools.de  
 Nr. - No.  
 60.6532M06IKDIMX85

Technische Änderungen vorbehalten!  
 Subject to technical modifications!  
 IDENT: DEWS132753

REV: -/B  
 MNR.

190736

