

Doppelverzahnung Lizenz Traub
double tooth system licence Traub

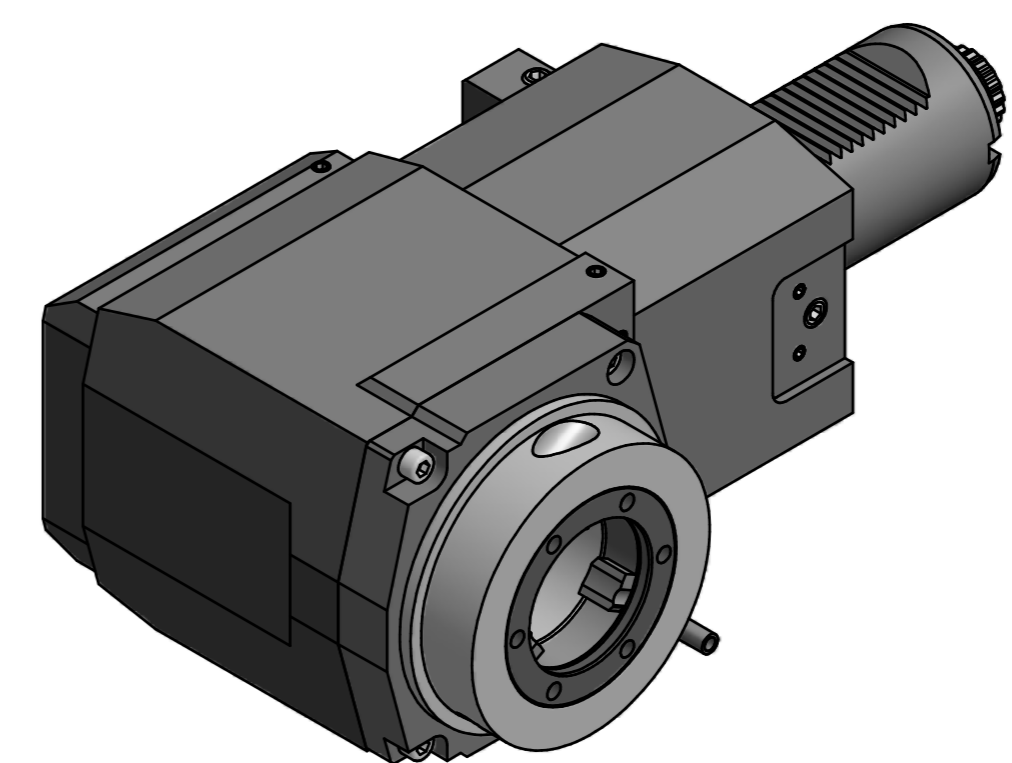

Copyright **EWS Tool Technologies**
Weitergabe und Vervielfältigung dieser Unterlage,
Verwertung und Mitteilung ihres Inhalts nicht
gestattet, soweit nicht ausdrücklich zugestanden.
Zuwendungen verpflichten zu Schadenersatz.

Bemerkung - Note mit Kegelrollenlager with taper roller bearing(s)	Technische Daten - technical data M ₁ / M ₂ = 80 / 160 Nm n ₁ / n ₂ = 4000 / 2000 1/min i (N ₁ :N ₂) = 2:1	Benennung - Title Radial Bohr und Fräskopf <i>Radial drilling and milling head</i>	name Schmid	date 25.03.2014	Technische Änderungen vorbehalten! Subject to technical modifications!
				Nr. 60.50V5KR5480RL2X145 <small>EWS EWS Weigte GmbH & Co. KG Maybachstr. 1 D-72096 Ulm/lingen Tel. +49(0)7161/93040-100</small>	
			MNR: 173627 IDENT: D-EWS-153728 - Blatt - page 1 (1)		

