

Spannzange / *collet* ER25 DIN6499
 Spannbereich / *clamping range*: 1,0 - 16,0

Gewindebohrzange / *tapping collet*
 ET-1-25 M3-M10

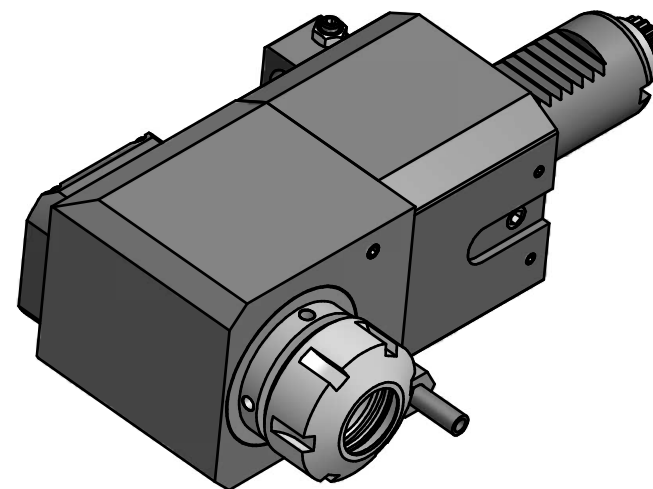

 Hakenschlüssel
 mit Zapfen
Hook wrench
 with fixed pin
 DIN1810 B 40x42

 Spannzangenschlüssel
Clamping wrench
 225

Copyright **EWS Tool Technologies**
 Weitergabe und Vervielfaeltigung dieser Unterlage,
 Verwertung und Mitteilung ihres Inhalts nicht
 gestattet, soweit nicht ausdrecklich zugestanden.
 Zuwiderhandlungen verpflichten zu Schadenersatz.

Bemerkung - *Note*

Technische Daten - *technical data*

Benennung - *Title*

M1 / M2 = 25 / 25 Nm
 n1 / n2 = 12000/12000 1/min
 i (N1:N2) = 1:1

Radial Bohr und Fräskopf
Radial drilling and milling head

	name	date
drawing	Theiss	27.03.2014

EWS EWS Weigete GmbH & Co. KG
 Maybachstr. 1
 D-73066 Uhingen
 Tel. +49(0)7161/93040-100

Technische Aenderungen vorbehalten!
 Subject to technical modifications!

Nr.
60.3025LCTXRLHSD12

MNR: 173683 IDENT: D-EWS-153939 - Blatt - page 1 (1)



DIN A3