

Spannzange / Collet ER16 DIN6499  
 Spannbereich / Clamping range: 1,0 - 10,0

Gewindebohrzange / Tapping Collet  
 ET-1-16 M1-M6

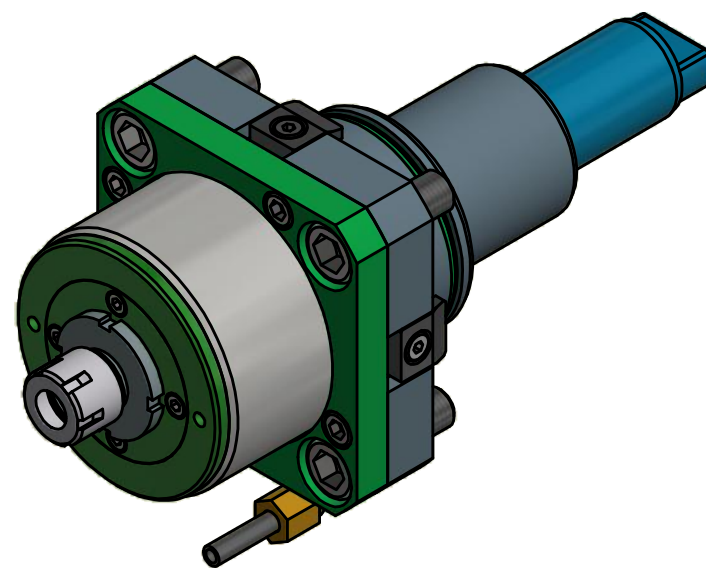

Fettschmierung mit Klüber Isoflex NCA 15  
 Alle 100 Betriebsstunden mit ca. 1cm<sup>3</sup> Fett nachschmieren  
*Grease lubrication with Klüber Isoflex NCA 15  
 relubricate every 100 operating hours with about 1cm<sup>3</sup> of grease*

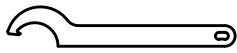

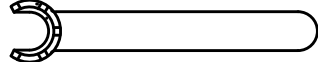
 Hakenschlüssel  
 mit Nase  
*Hook wrench with  
 nose end*  
 DIN1810 A 36x38

 Spannzangenschlüssel  
*Clamping wrench*  
 216 M

Copyright **EWS Tool Technologies**  
 Weitergabe und Vervielfaeltigung dieser Unterlage,  
 Verwertung und Mitteilung ihres Inhalts nicht  
 gestattet, soweit nicht ausdrecklich zugestanden.  
 Zuwiderhandlungen verpflichten zu Schadenersatz.

Bemerkung - Note	Technische Daten - technical data Weight = 4.579 [kg] Torque max. (M1/M2) = 25/5 [Nm] Speed max. (n1/n2) = 4800 / 24000 [1/min] Gear ratio (i)=n1:n2 = 1:5	Benennung - Title Axial Bohr und Fräskopf Axial drilling and milling head	 <b>EWS</b> Tool Technologies <small>EWS Weigele GmbH &amp; Co. KG          Maybachstr. 1          D-73066 UHINGEN          www.ews-tools.de</small>	Technische Aenderungen vorbehalten! Subject to technical modifications! IDENT: D-EWS-217453 Nr. - No. 40.6516VT4I15	 REV: -/- MNR. 197737	
------------------	--	---	---	---	---	---