

Schwenkbereich  $\pm 105^\circ$   
Swivel area  $\pm 105^\circ$

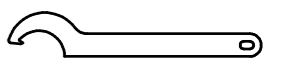

Spannzange / Collet ER16 DIN6499  
Spannbereich / Clamping range: 1,0 - 10,0

Gewindebohrzange / Tapping Collet  
ET-1-16 M1-M6

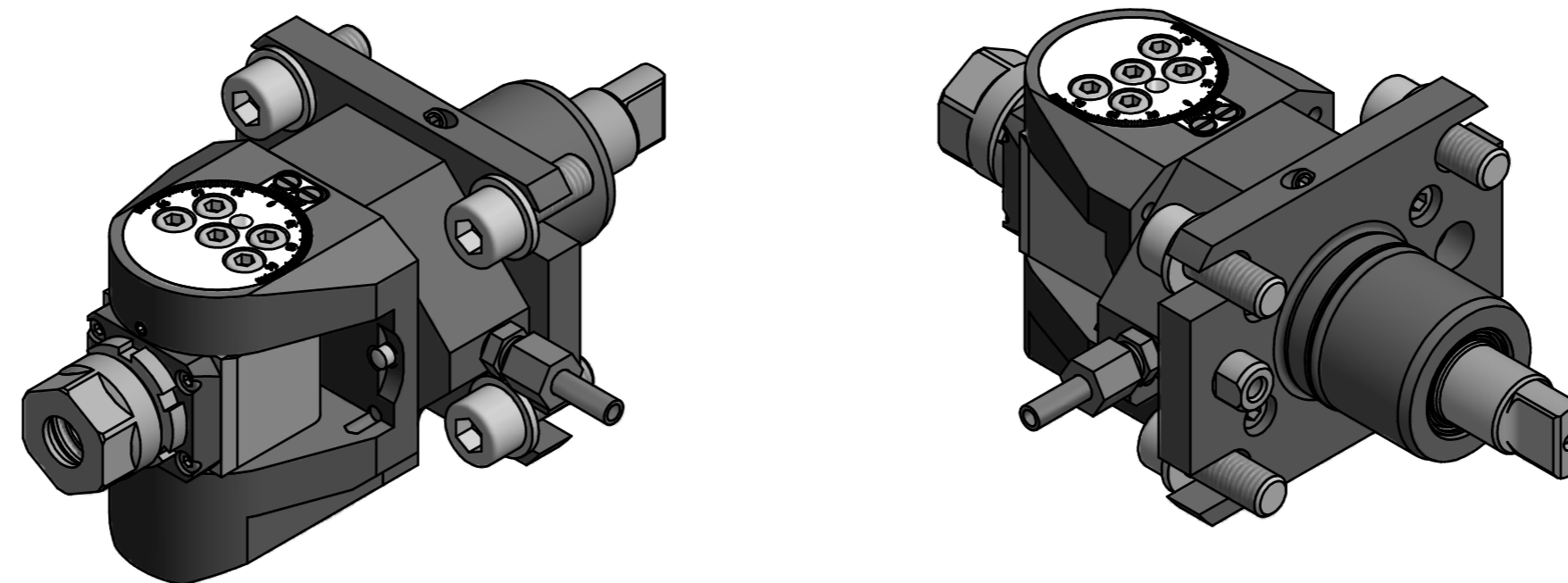
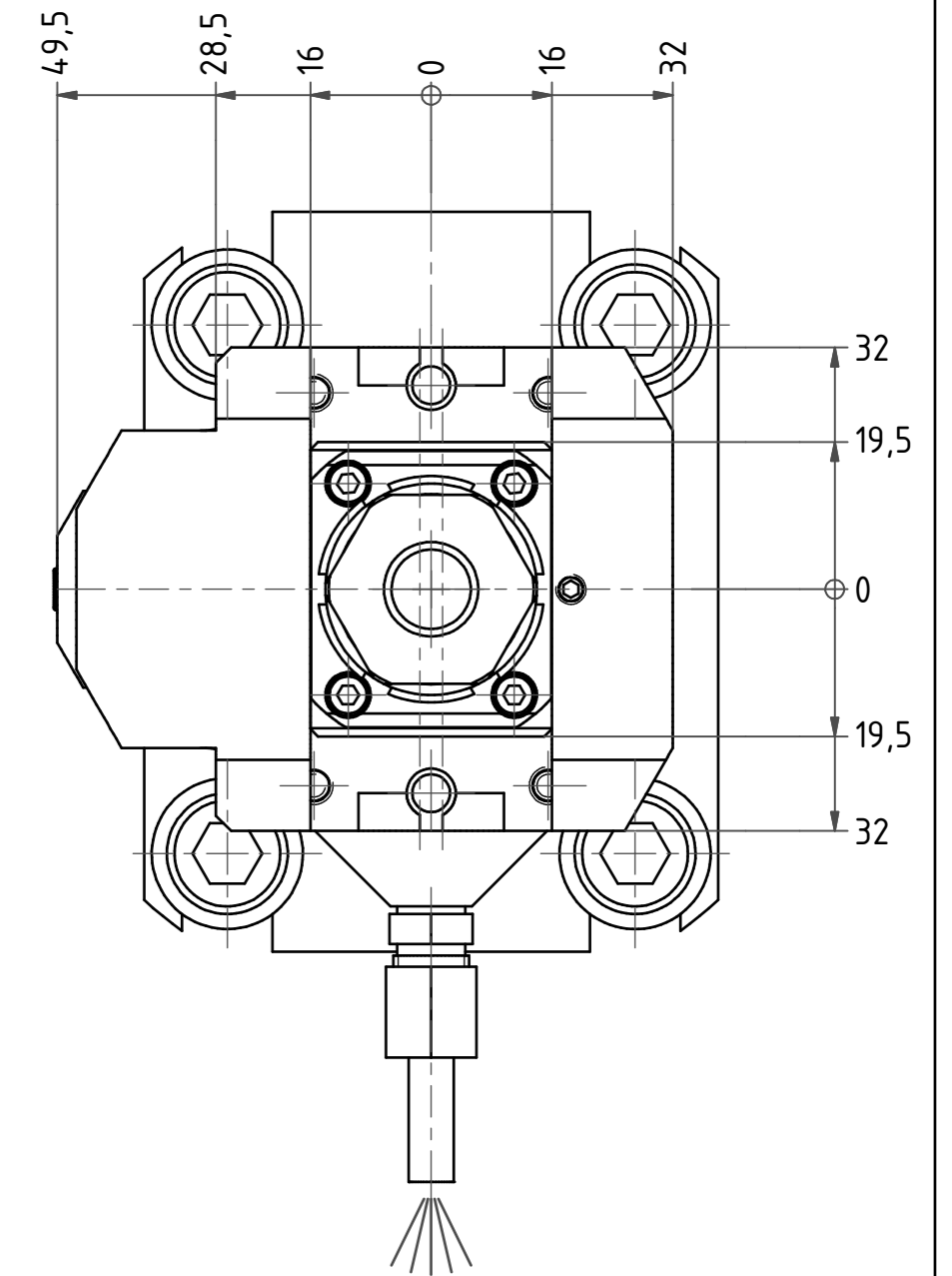

Hakenschlüssel  
mit Nase  
Hook wrench with  
nose end  
DIN1810 A 30x32

Copyright **EWS Tool Technologies**  
Weitergabe und Vervielfältigung dieser Unterlage,  
Verwertung und Mitteilung ihres Inhalts nicht  
gestattet, soweit nicht ausdrücklich zugestanden.  
Zu widerhandlungen verpflichten zu Schadenersatz.

Bemerkung - Note	Technische Daten - technical data <b>Weight</b> = 3.090 [kg] <b>Torque max. (M1/M2)</b> = 16 / 8 [Nm] <b>Speed max. (n1/n2)</b> = 6000 / 12000 [1/min] <b>Gear ratio (i)=n1:n2</b> = 1:2	Benennung - Title <b>Schwenkkopf</b> <b>Swivel head</b>	 <b>EWS</b> Weigle GmbH & Co. KG Maybachstr. 1 D-73066 Uhringen www.ews-tools.de Nr. - No. <b>63.4016MT1211</b>	Technische Änderungen vorbehalten! Subject to technical modifications! IDENT: D-EWS-215870 MNR. <b>197596</b>	
------------------	--	---	---	---	---