

Spannzange / collet ER25 DIN6499  
Spannbereich / clamping range: 1,0 - 16,0

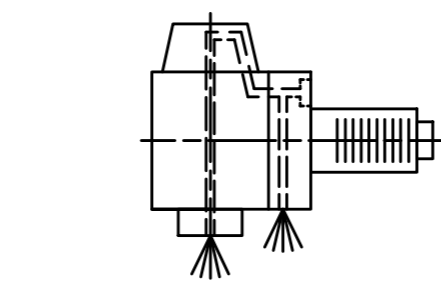

Innen- und Aussenkuehlung / Inside and outside coolant supply  
Kuehlmittefiltrierung=50µ / coolant filtration=50µ

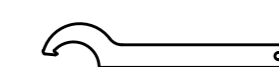
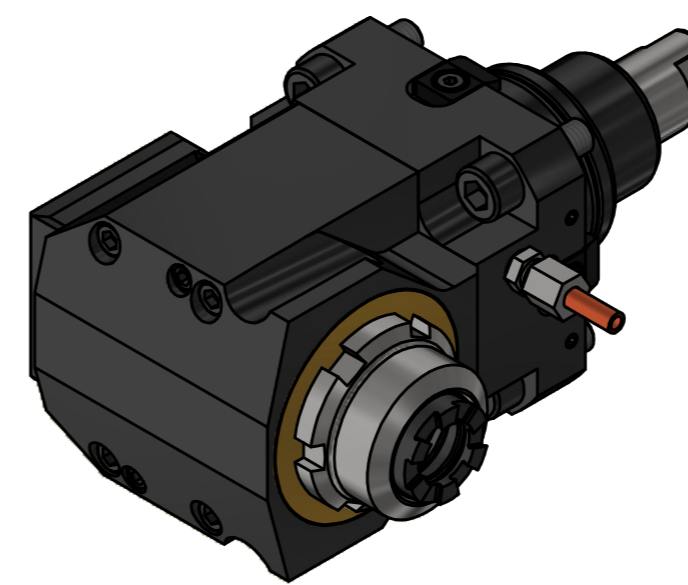

Hakenschlüssel  
mit Nase  
Hook wrench with  
nose end  
DIN1810 A 52x55

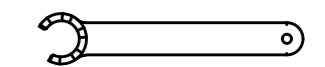

Spannzangenschlüssel für  
innenliegende Mutter  
Clamping wrench for  
internal collet  
225AX

Copyright **EWS Tool Technologies**  
Weitergabe und Vervielfaeltigung dieser Unterlage,  
Verwertung und Mitteilung ihres Inhalts nicht  
gestattet, soweit nicht ausdrecklich zugestanden.  
Zuwiderhandlungen verpflichten zu Schadenersatz.

Bemerkung - Note  
Für Trockenlauf geeignet!  
Use without coolant fluid allowed!

Technische Daten - technical data  
Weight = 6.559 [kg]  
Torque max. (M1/M2) = 50 / 50 [Nm]  
Speed max. (n1/n2) = 6000 / 6000 [1/min]  
Gear ratio (i)=n1:n2 = 1:1  
Pressure (pmax) = 70 [bar]

Benennung - Title  
**Radial Bohr und Fräskopf**  
**Radial drilling and milling head**

**EWS** Tool Technologies  
EWS Weigle GmbH & Co. KG  
Maybachstr. 1  
D-73066 Uhingen  
www.ews-tools.de  
Technische Aenderungen vorbehalten!  
Subject to technical modifications!  
IDENT: DEWS039652  
REV: -/B  
MNR.  
197491

