

Spannzange / Collet ER16 DIN6499  
 Spannbereich / Clamping range: 1,0 - 10,0

Gewindebohrzange / Tapping Collet  
 ET-1-16 M1-M6

Trifix Anzugsdrehmoment 10 Nm  
 Trifix clamping torque 10 Nm

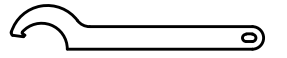
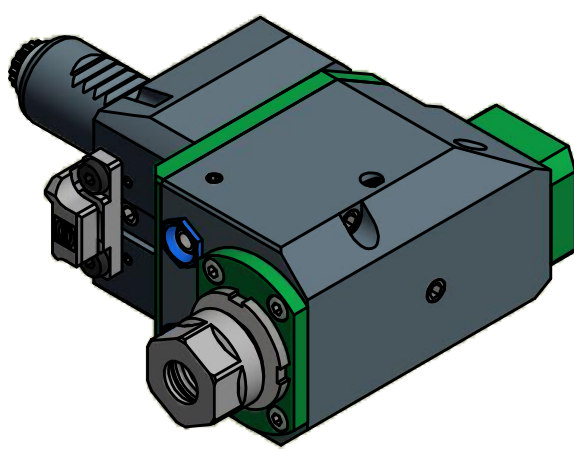
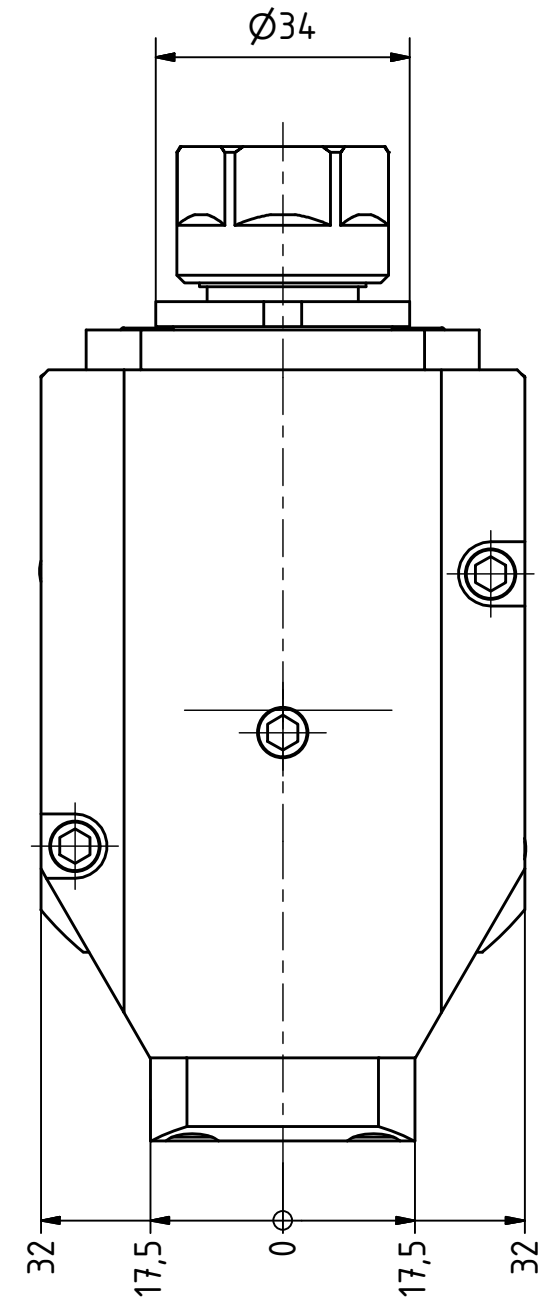
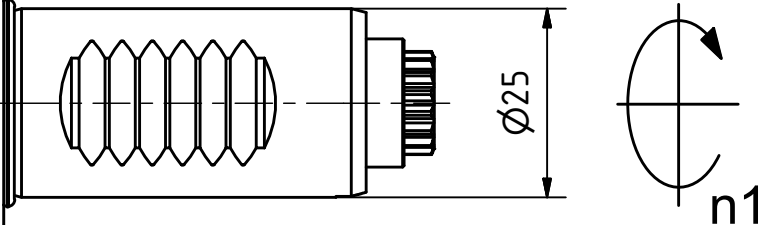

Hakenschlüssel  
 mit Nase  
 Hook wrench with  
 nose end  
 DIN1810 A 34x36

Copyright **EWS Tool Technologies**  
 Weitergabe und Vervielfaeltigung dieser Unterlage,  
 Verwertung und Mitteilung ihres Inhalts nicht  
 gestattet, soweit nicht ausdrecklich zugestanden.  
 Zuwiderhandlungen verpflichten zu Schadenersatz.

Bemerkung - Note

Technische Daten - technical data  
 Weight = 3.464 [kg]  
 Torque max. (M1/M2) = 15 / 5 [Nm]  
 Speed max. (n1/n2) = 6000 / 18000 [1/min]  
 Gear ratio (i)=n1:n2 = 1:3

Benennung - Title  
 Radial Bohr und Fräskopf  
 Radial drilling and milling head

**EWS** Tool Technologies  
 EWS Weigle GmbH & Co. KG  
 Maybachstr. 1  
 D-73066 UHINGEN  
 www.ews-tools.de

Technische Aenderungen vorbehalten!  
 Subject to technical modifications!  
 IDENT: DEWS037928  
 Nr. - No. 60.2516L5480LI13TF

REV: -/A  
 MNR. 162726

