

Spannzange / collet ER32 DIN6499
 Spannbereich / clamping range: 2,0 - 20,0

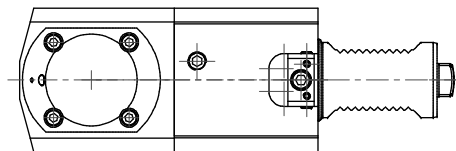

Doppelverzahnung Lizenz Traub
 double tooth system licence Traub

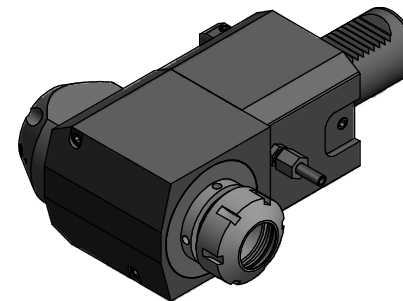
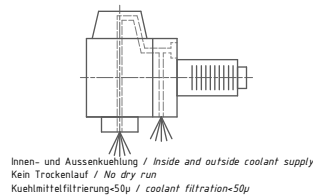

Innen- und Aussenkuehlung / Inside and outside coolant supply
 Kein Trockenlauf / No dry run
 Kuehlmittelfiltrierung=50µ / coolant filtration=50µ

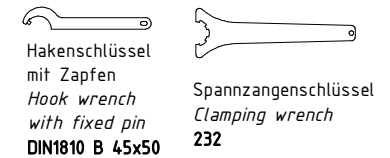

Copyright EWS Tool Technologies
 Weitergabe und Vervielfaeltigung dieser Unterlage,
 Verwertung und Mitteilung ihres Inhalts nicht
 gestattet, soweit nicht ausdrecklich zugestanden.
 Zuwiderhandlungen verpflichten zu Schadenersatz.

Bemerkung - Note

Nicht ohne Kuehlmittel betreiben!
 Not for use without coolant-fluid!

Technische Daten - Technical data

Weight = 7.744 [kg]
 Torque max. (M1/M2) = 50 / 50 [Nm]
 Speed max. (n1/n2) = 6000 / 6000 [1/min]
 Gear ratio (i1=n1:n2) = 1:1
 Pressure (pmax) = 70 [bar]

Benennung - Title

Radial Bohr und Fräskopf
 Radial drilling and milling head



60.40321809RLIKPIN56X120

Technische Änderungen vorbehalten!
 Subject to technical modifications!
 IDENT: D-EWS-191250



REV: -/-
 1/18

