

Schwenkbereich  $\pm 92^\circ$   
Swivel area  $\pm 92^\circ$

Spannzange / Collet ER16 DIN6499  
Spannbereich / Clamping range: 1,0 - 10,0

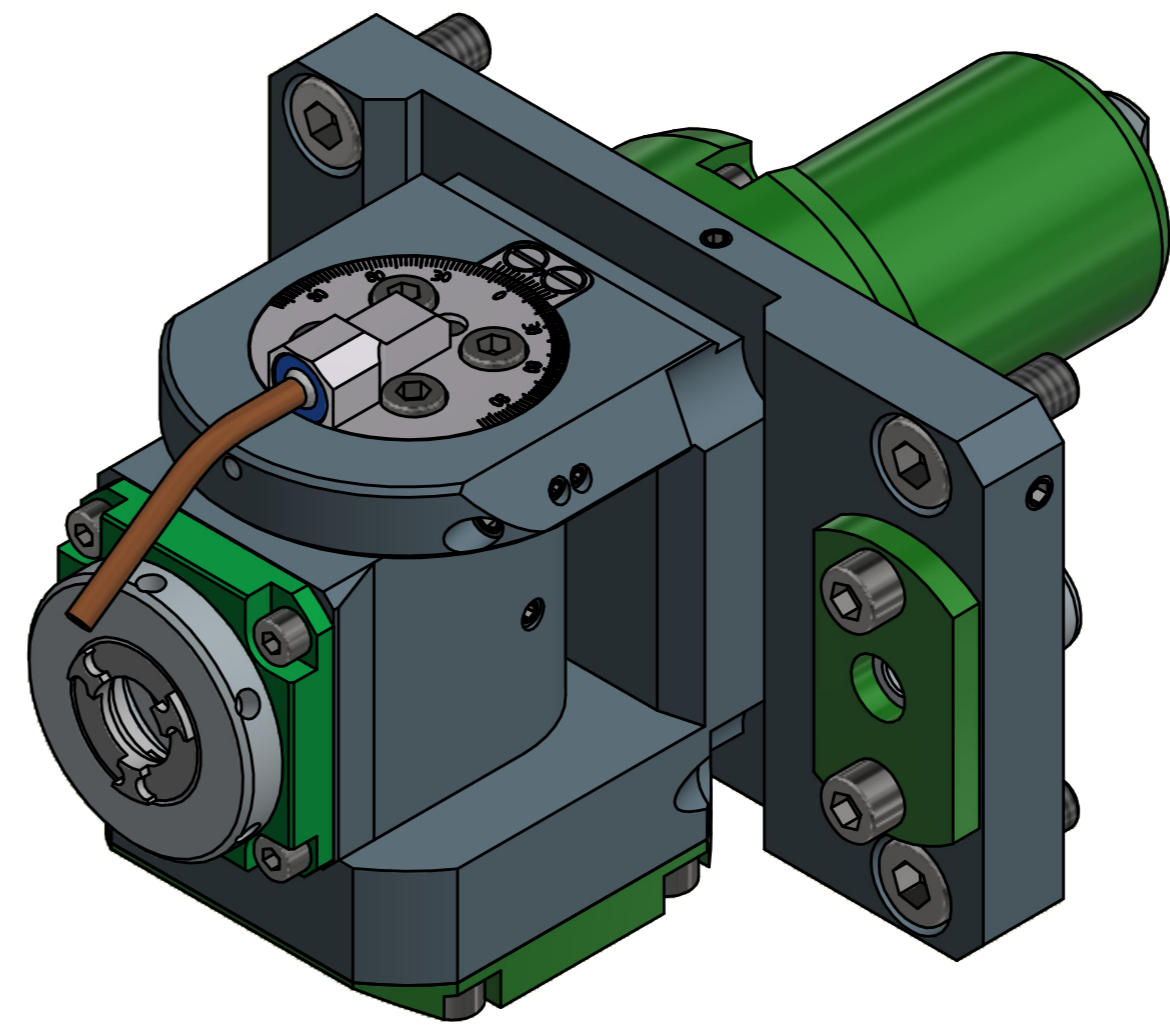
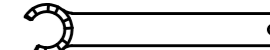

  
Hakenschlüssel  
mit Zapfen  
Hook wrench  
with fixed pin  
DIN1810 B 40x42

  
Spannzangenschlüssel für  
innenliegende Mutter  
Clamping wrench for  
internal collet  
216AX

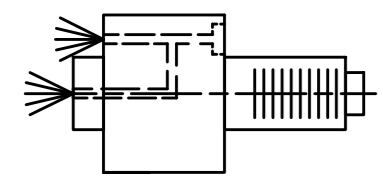

Copyright EWS Tool Technologies  
Weitergabe und Vervielfältigung dieser Unterlage,  
Verwertung und Mitteilung ihres Inhalts nicht  
gestattet, soweit nicht ausdrücklich zugestanden.  
Zuwendungen verpflichten zu Schadenersatz.



Innen- und Aussenkuehlung / Inside and outside coolant supply  
Kein Trockenlauf / No dry run  
Kuehlmittelfiltrierung  $< 50\mu$  / coolant filtration  $< 50\mu$

Bemerkung - Note	Technische Daten - technical data
Nicht ohne Kuehlmittel betreiben! Not for use without coolant-fluid!	Weight = 4,288 [kg] Torque max. (M1/M2) = 16 / 16 [Nm] Speed max. (n1/n2) = 6000 / 6000 [1/min] Gear ratio (i)=n1:n2 = 1:1 Pressure (pmax) = 70 [bar]

Benennung - Title
<b>Schwenkkopf</b> <b>Swivel head</b>

 <b>EWS</b> Weigle GmbH & Co. KG Maybachstr. 1 D-73066 Uhlingen www.ews-tool.de	Technische Aenderungen vorbehalten! Subject to technical modifications! IDENT: DEWS123602	 REV: -/A MNR.
	Nr. - No. <b>63.6816QSMBMTIKIM</b>	<b>173168</b>

