

Highspeed

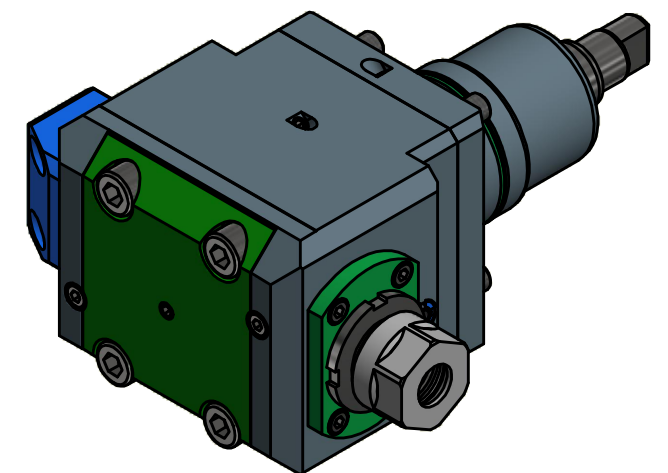

Tech Details

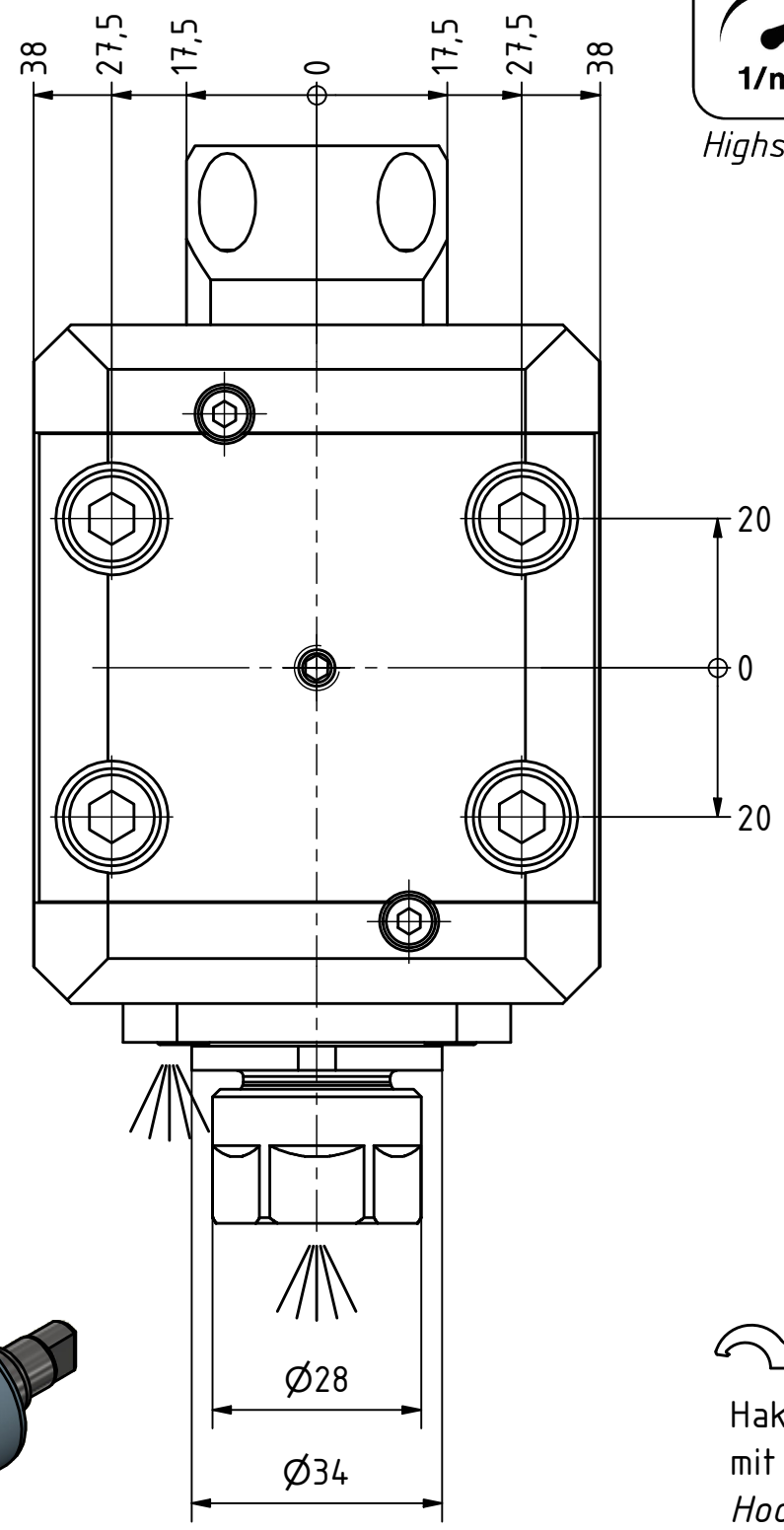
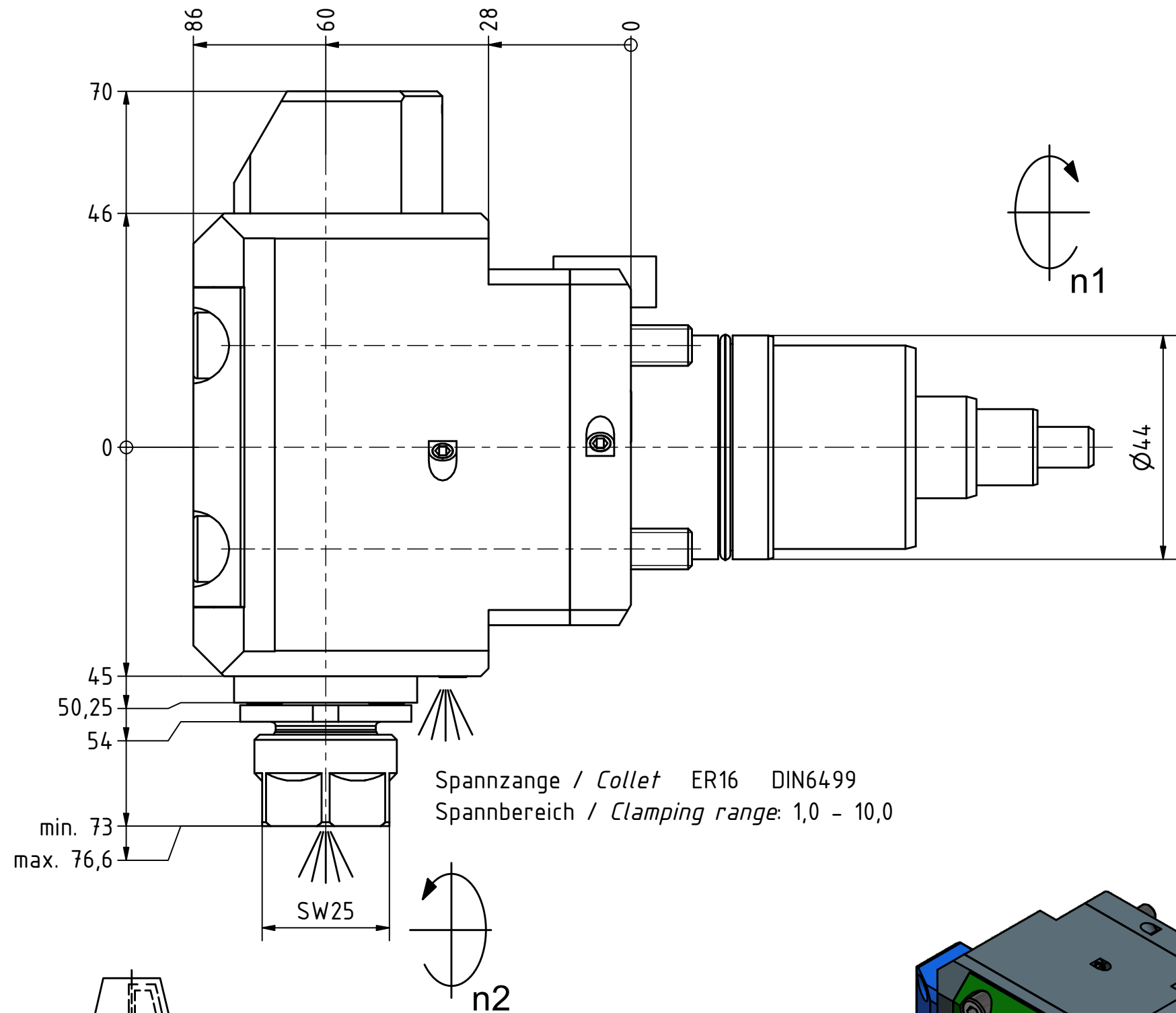
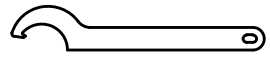

 Hakenschlüssel
 mit Nase
 Hook wrench with
 nose end
 DIN1810 A 34x36

Innen- und Aussenkuehlung / Inside and outside coolant supply
 Kuehlmittelfiltrierung 50μ / coolant filtration 50μ

Copyright **EWS Tool Technologies**
 Weitergabe und Vervielfaeltigung dieser Unterlage,
 Verwertung und Mitteilung ihres Inhalts nicht
 gestattet, soweit nicht ausdrecklich zugestanden.
 Zuwiderhandlungen verpflichten zu Schadenersatz.

Bemerkung - Note
 Nicht ohne Kuehlmittel betreiben!
 Not for use without coolant-fluid!

Technische Daten - technical data	
Weight	= 4.556 [kg]
Torque max. (M1/M2)	= 15 / 5 [Nm]
Speed max. (n1/n2)	= 6000 / 18000 [1/min]
Gear ratio (i)=n1:n2	= 1:3
Pressure (pmax)	= 70 [bar]

Benennung - Title
Radial Bohr und Fräskopf
Radial drilling and milling head

EWS Tool Technologies
 EWS Weigle GmbH & Co. KG
 Maybachstr. 1
 D-73066 Uehingen
 www.ews-tools.de

Nr. - No.
60.44.16NTY3IK113

Technische Aenderungen vorbehalten!
 Subject to technical modifications!

IDENT: DEWS133223

REV: -/A

MNR.
189398

