

Spannzange / collet ER32 DIN6499  
Spannbereich / clamping range: 2,0 - 20,0

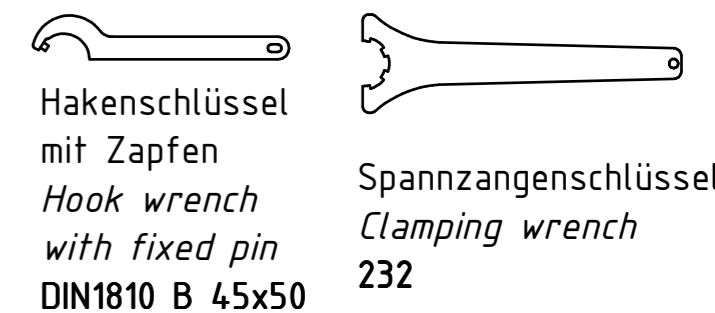
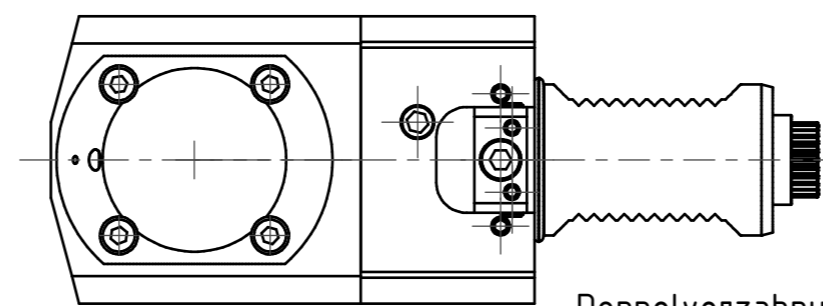
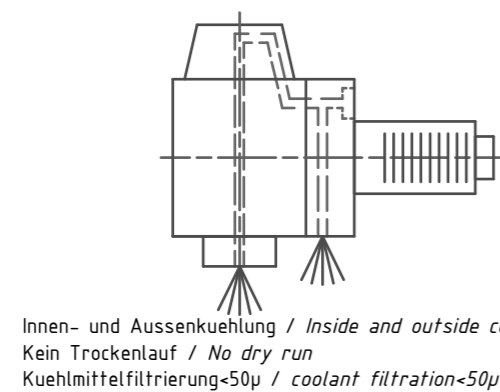
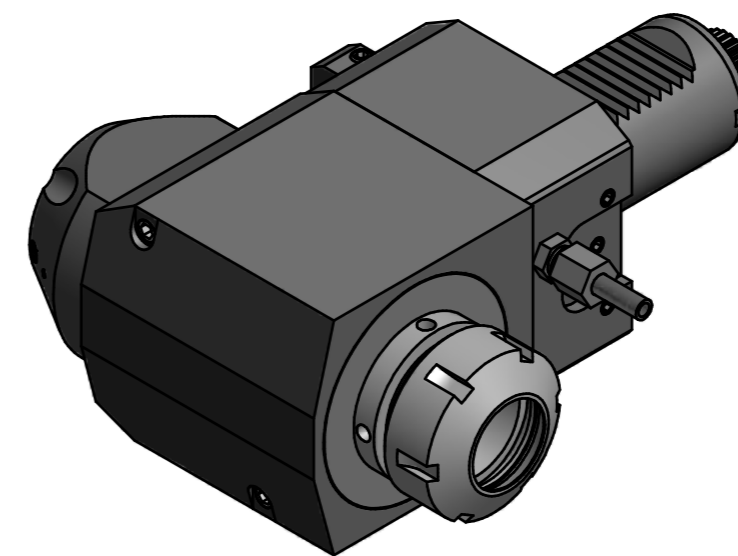
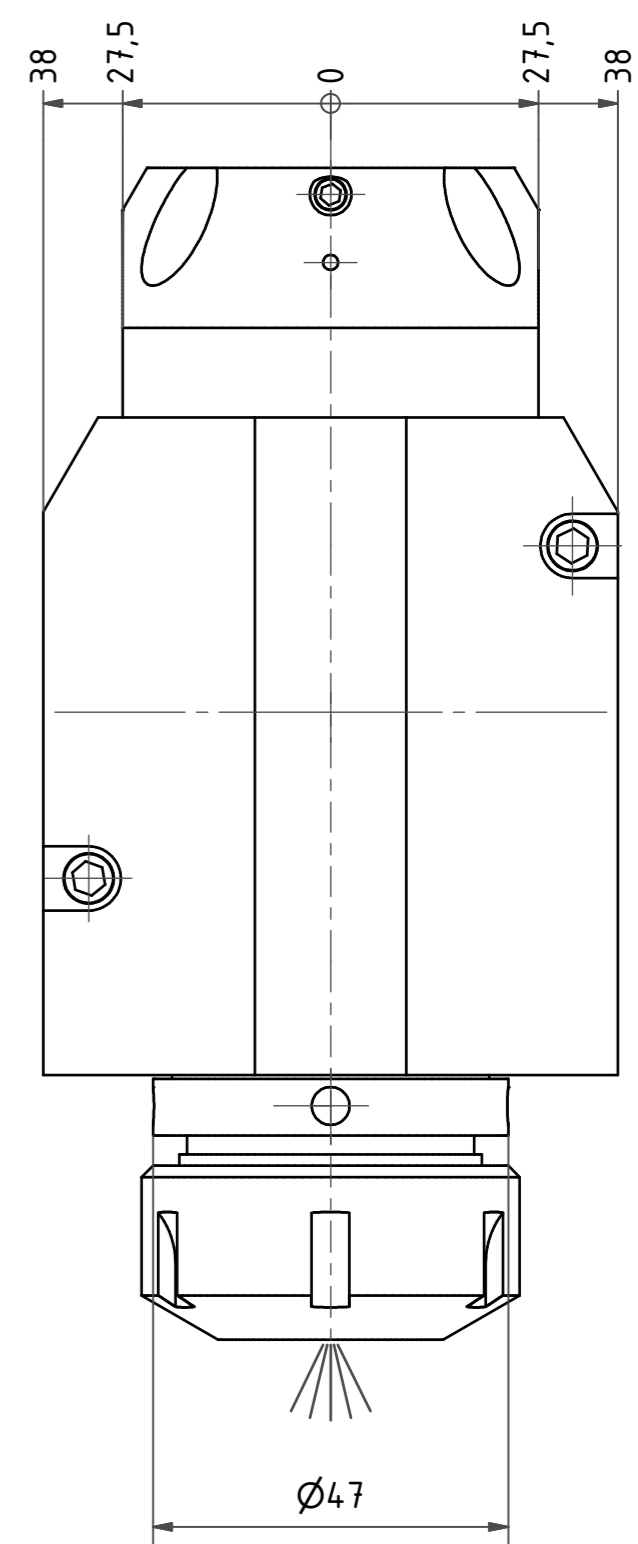

Copyright **EWS Tool Technologies**  
Weitergabe und Vervielfaeltigung dieser Unterlage, Verwertung und Mitteilung ihres Inhalts nicht gestattet, soweit nicht ausdrecklich zugestanden. Zuwiderhandlungen verpflichten zu Schadenersatz.

Bemerkung - Note  
Nicht ohne Kuehlmittel betreiben!  
Not for use without coolant-fluid!

Technische Daten - Technical data  
M1 / M2 = 50 / 50 Nm  
n1 / n2 = 6000 / 6000 1/min  
i (N1:N2) = 1:1  
Pmax = 70 bar

Benennung - Title  
**Radial Bohr und Fräskopf**  
**Radial drilling and milling head**

|               |            |
|---------------|------------|
| name          | date       |
| M. Simoniello | 04.08.2014 |

drawing

Technische Aenderungen vorbehalten!  
Subject to technical modifications!

Nr.  
**60.4032CTXRLIK-CBX90**

MNR: 166231 IDENT: D-EWS-160838 - Blatt - page 1 (1)

DIN A2