

Fraeserwelle austaschbar
Spindle removable

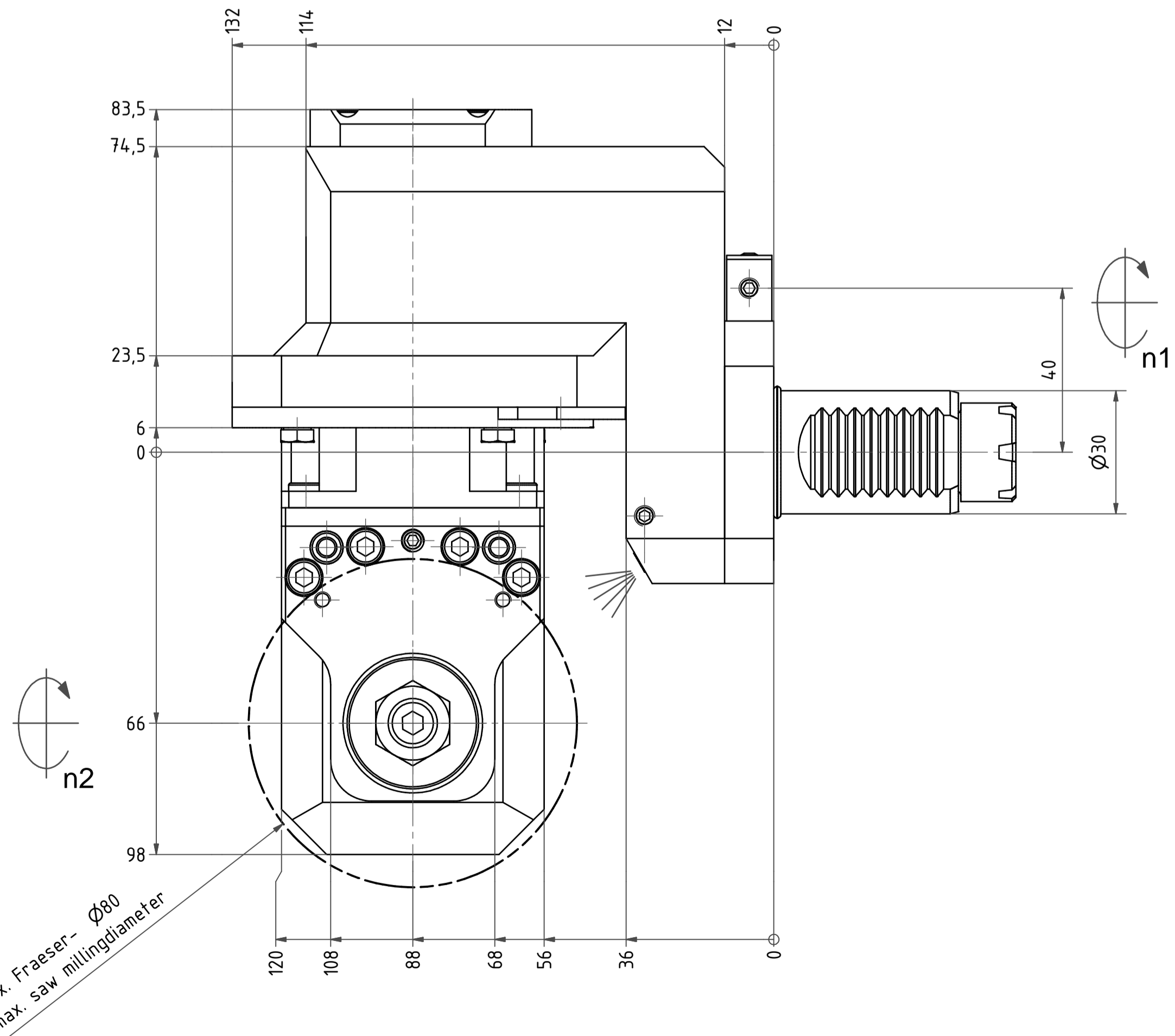

max. Fräseser - Ø80
max. saw milling diameter

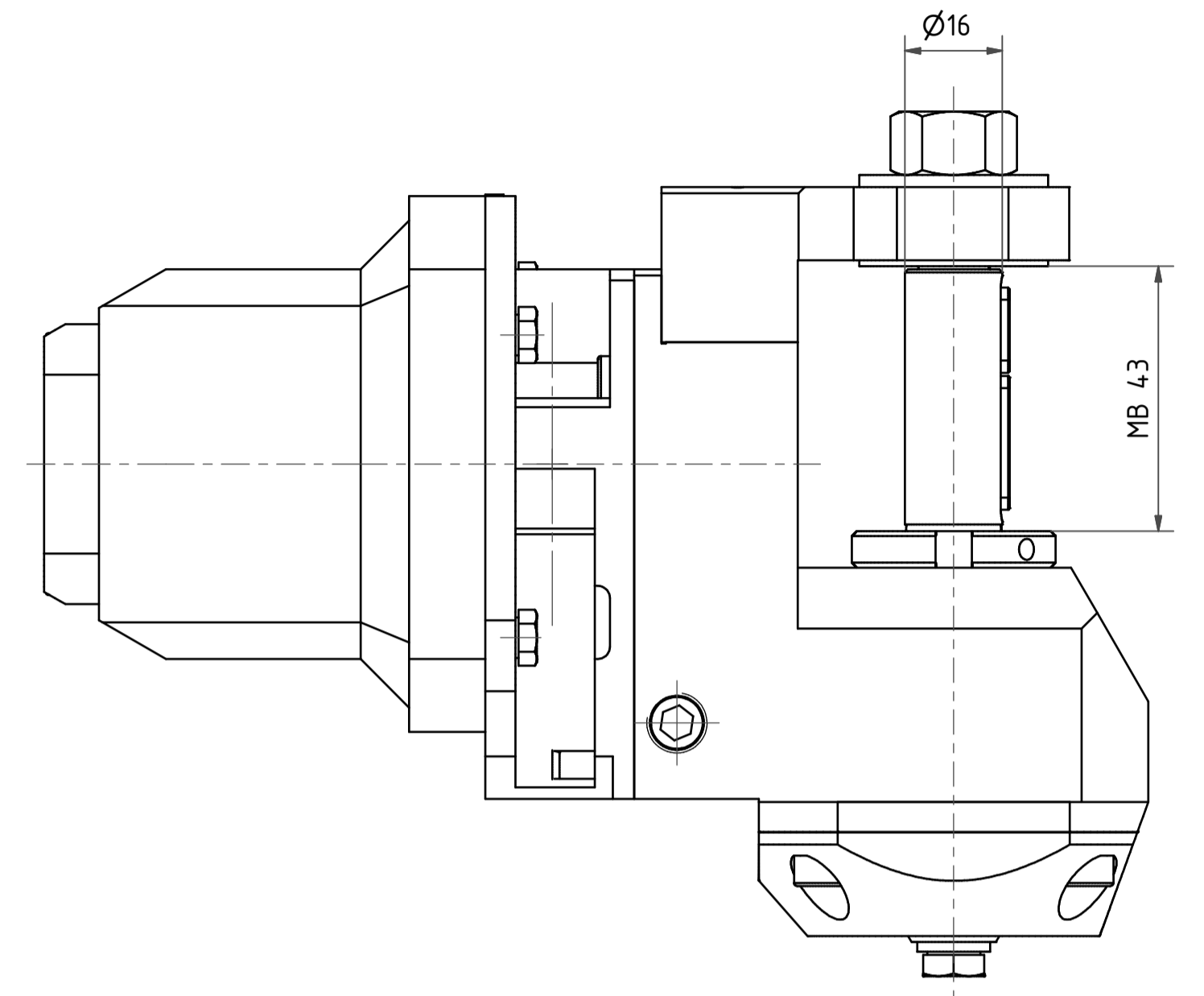
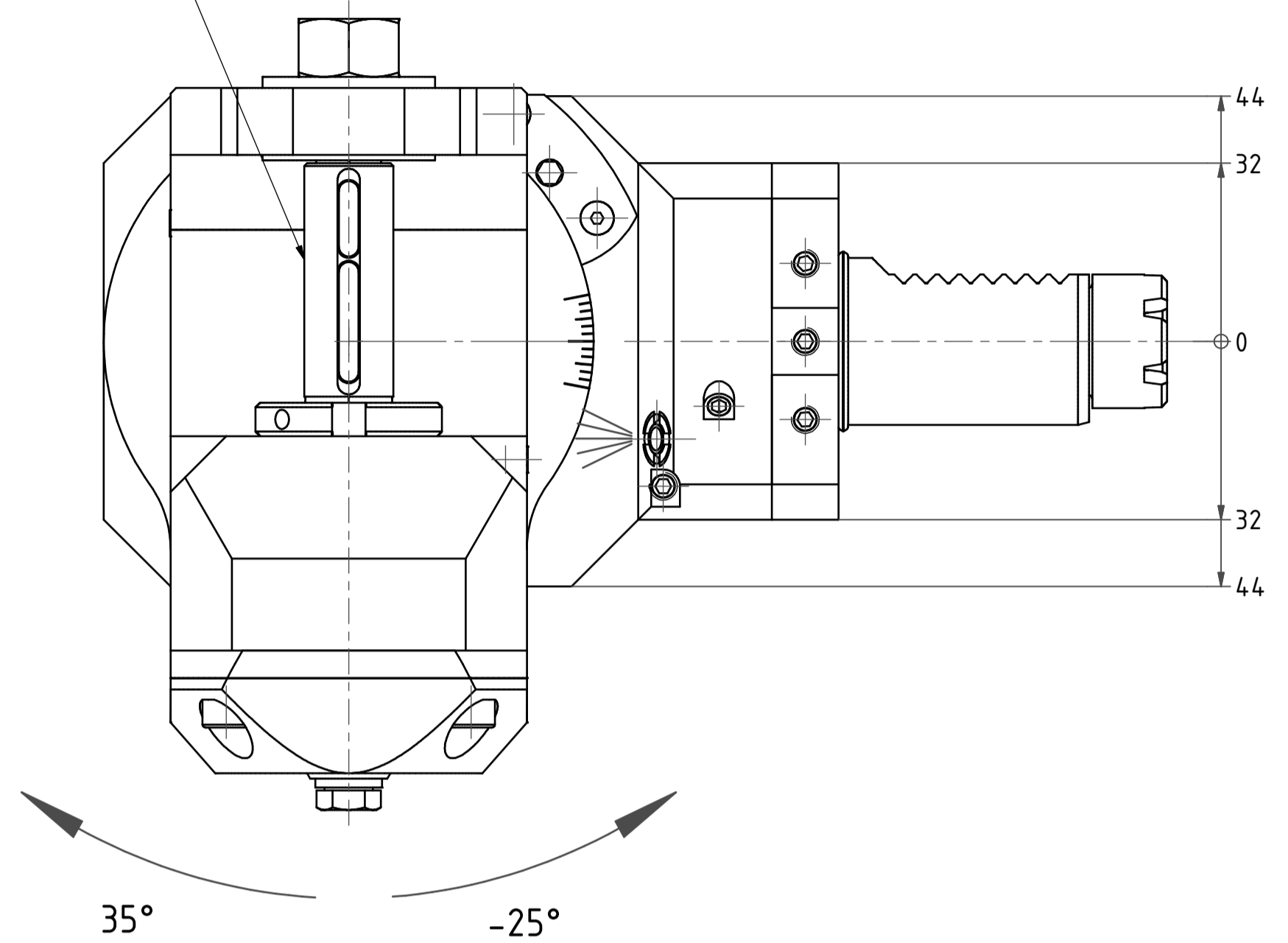
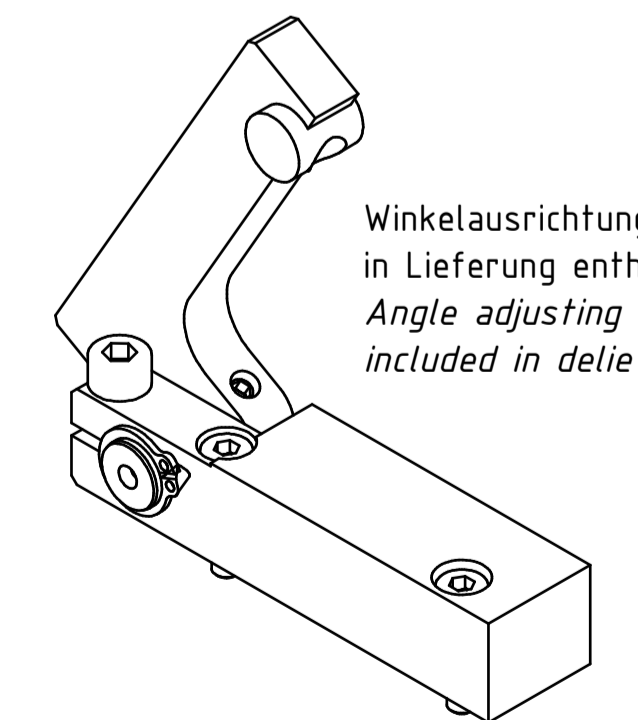
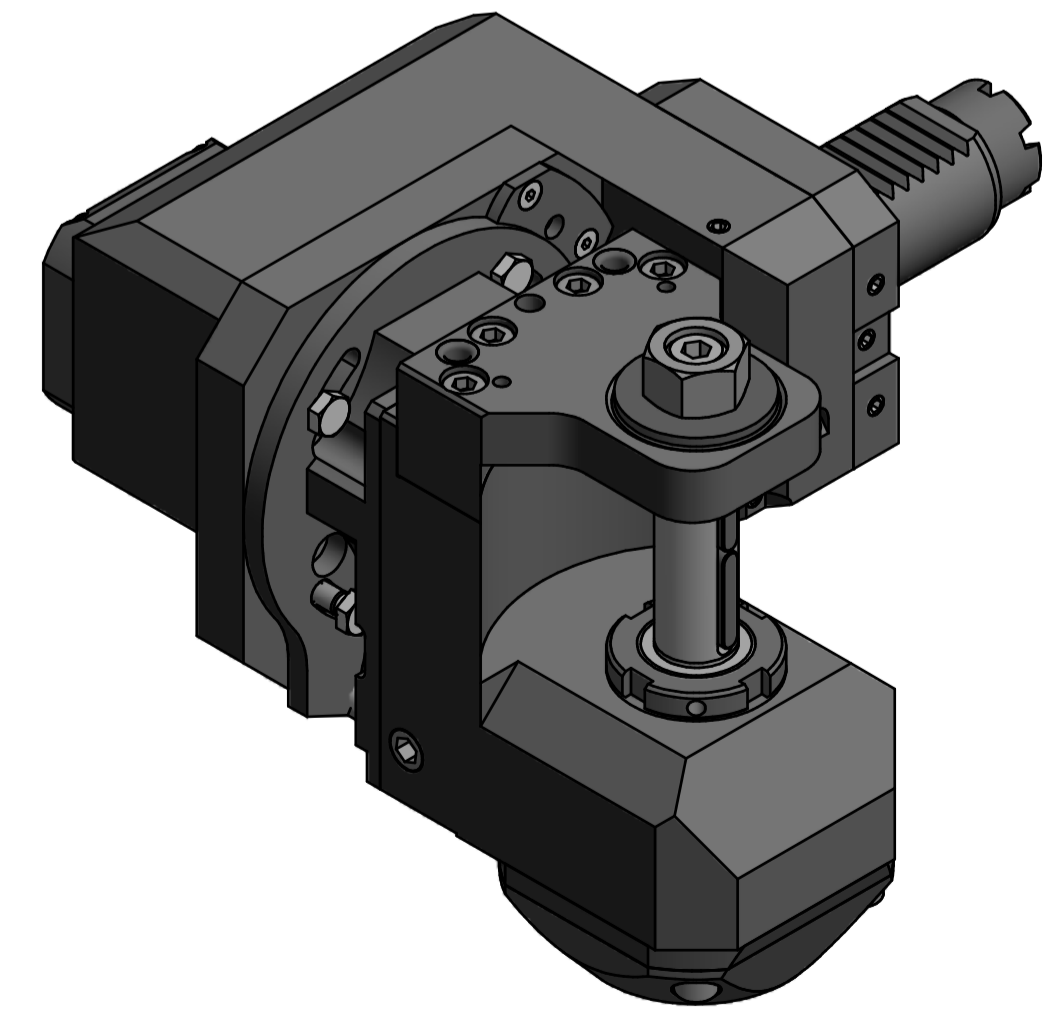

Winkelausrichtung & CD-ROM
in Lieferung enthalten!
Angle adjusting & CD-ROM
included in delievery!

| | |
|---------------------|--|
| Bezeichnung - Title | Technische Daten - technical data |
| | Weight = 7.588 [kg] |
| | Torque max. (M1/M2) = 20 / 60 [Nm] |
| | Speed max. (n1/n2) = 6000 / 2000 [1/min] |
| | Gear ratio (i)=n1:n2 = 3:1 |

| | |
|--|---|
| Bezeichnung - Title | Technische Änderungen vorbehalten! Subject to technical modifications! |
| Radial Scheibenfräserkopf versetzt Saw milling spindle offset | IDENT: D-EWS-134.223 |

| | | |
|--------------------------|---|----------|
| EWS Tool Technologies | EWS Werkzeug GmbH & Co. KG Hauptstr. 1 57208 Brüggen www.ews-td.de | REV: A/- |
| Nr. - No. | 84.3016TOEMR13TKWMB4.3 | 166182 |

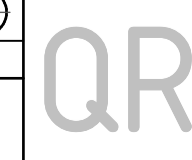

Copyright EWS Tool Technologies
Weitergabe und Vervielfältigung dieser Unterlage,
Verwertung und Mitteilung ihres Inhalts nicht
gestattet, soweit nicht ausdrücklich zugestanden.
Zuwendungen verpflichten zu Schadenersatz.