

Spannzange / collet ER50 DIN6499  
 Spannbereich / clamping range: 6,0 - 34,0

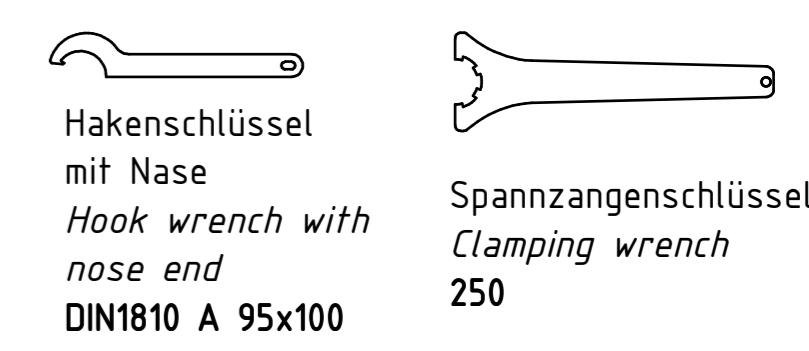
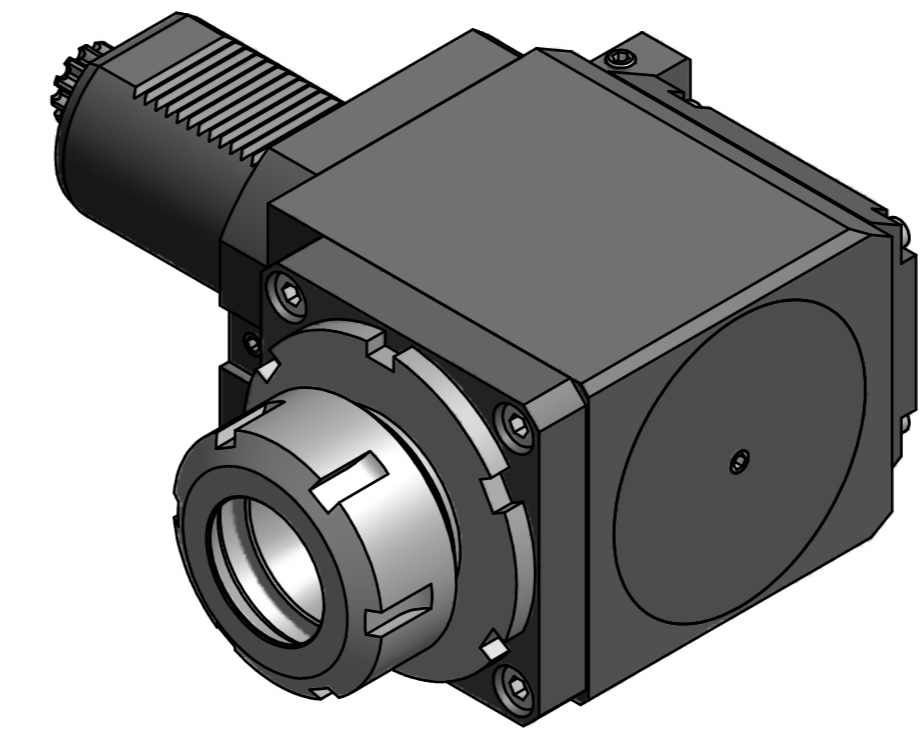
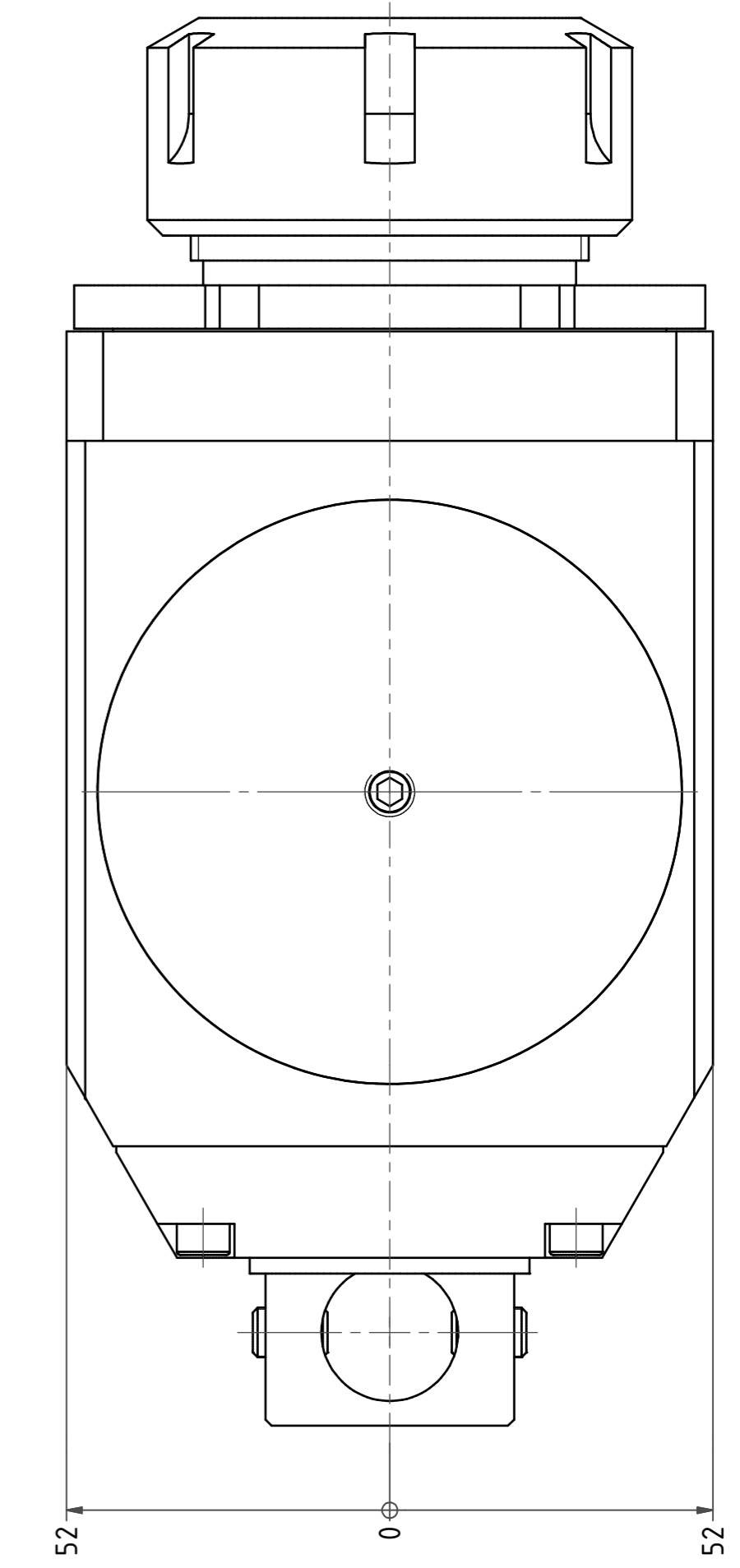
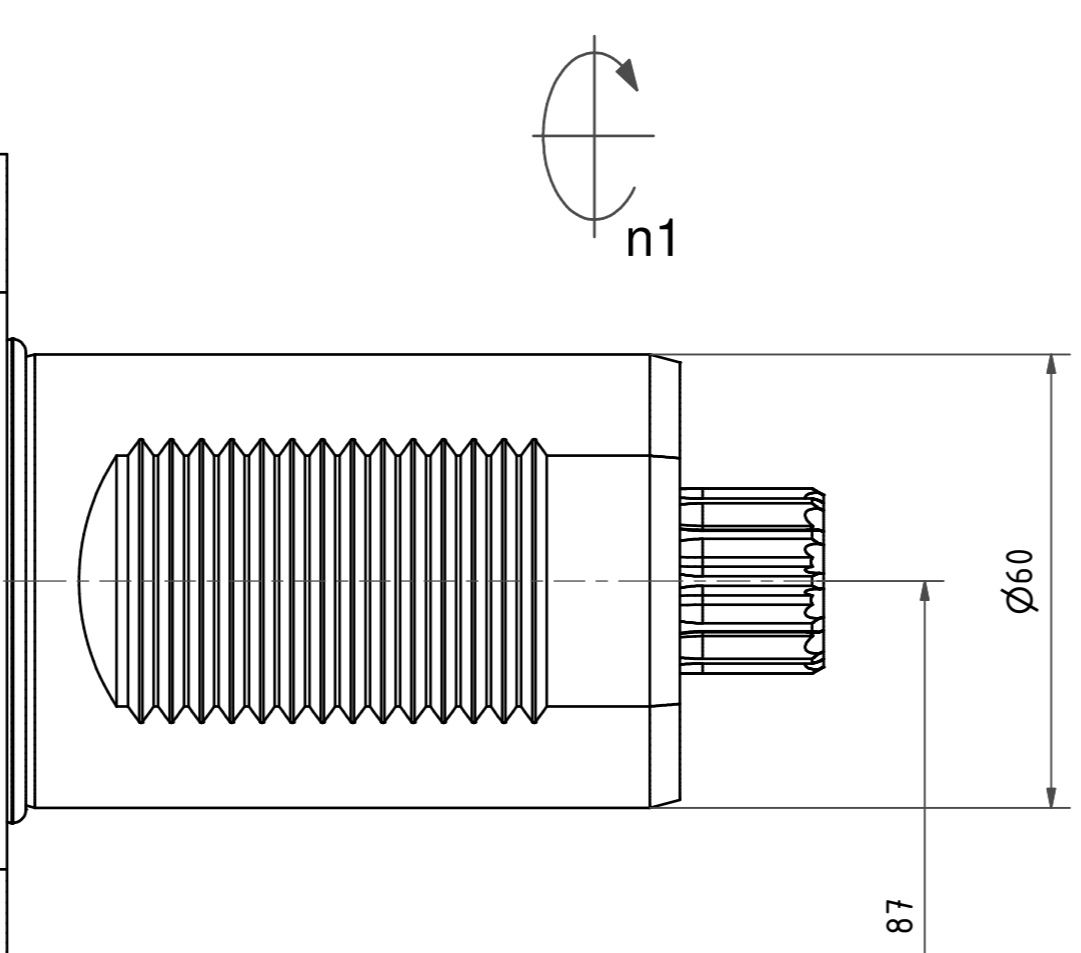

Copyright **EWS Tool Technologies**  
 Weitergabe und Vervielfältigung dieser Unterlage,  
 Verwertung und Mitteilung ihres Inhalts nicht  
 gestattet, soweit nicht ausdrücklich zugestanden.  
 Zuwiderhandlungen verpflichten zu Schadenersatz.

Bemerkung - Note		Technische Daten - technical data		Benennung - Title		name		date		Technische Änderungen vorbehalten! Subject to technical modifications!			
mit Kegelrollenlager with taper roller bearing(s)		M <sub>1</sub> / M <sub>2</sub> = 160 / 160 Nm n <sub>1</sub> / n <sub>2</sub> = 3000 / 3000 1/min i (N <sub>1</sub> :N <sub>2</sub> ) = 1:1		Radial Bohr und Fräskopf Radial drilling and milling head		Schmid		18.08.2014		Nr. <b>60.6050KR5482L</b>			DIN A2
						EWS Tool Technologies		EWS Werkzeug GmbH & Co. KG Maybachstr. 1 D-72096 Löhningen Tel. +49(0)7161/93040-100		MNR: 172749		IDENT: D-EWS-161727 -	Blatt - page 1 (1)