

Innen- und Aussenkuehlung / Inside and outside coolant supply
 Kein Trockenlauf / No dry run
 Kuehlmittelfiltrierung-50µ / coolant filtration-50µ

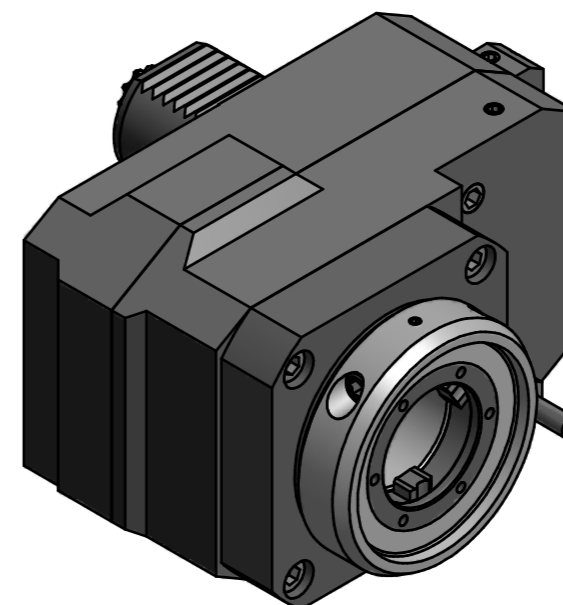

Copyright **EWS Tool Technologies**
 Weitergabe und Vervielfaeltigung dieser Unterlage,
 Verwertung und Mitteilung ihres Inhalts nicht
 gestattet, soweit nicht ausdruercklich zugestanden.
 Zuwiderhandlungen verpflichten zu Schadenersatz.

Bemerkung - Note Nicht ohne Kuehlmittel betreiben! Not for use without coolant-fluid! mit Kegelrollenlager with taper roller bearing	Technische Daten - Technical data M1 / M2 = 40 / 80 Nm n1 / n2 = 6000 / 3000 1/min i (N1:N2) = 1,963:1 Pmax = 70 bar	Benennung - Title Axial Bohr u. Fräskopf achsversetzt Ax. drill. and mill. head offset	name Theiss	date 09.01.2014	Technische Aenderungen vorbehalten! Subject to technical modifications! Nr. 50.40VX4KR5482LIK12 File: D-EWS-149612-.idw	Weigle GmbH & Co. KG Maybachstr. 1 D-73066 Ulmungen Tel. +49(0)7161/93040-10	DIN A2 Blatt - page 1 (1)
			drawing				