

1 Ausrichtpin muß entfernt werden.  
1 adjusting pin must be removed.

Beide Nachbarstationen könnten entfallen!  
both neighbouring stations may be lost!

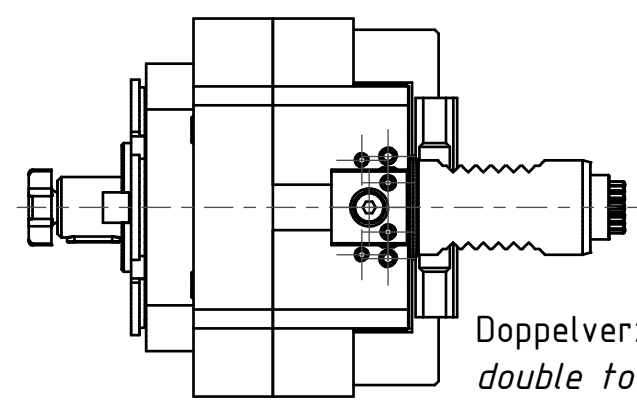

Doppelverzahnung Lizenz Traub  
double tooth system licence Traub

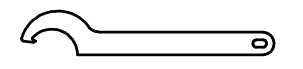
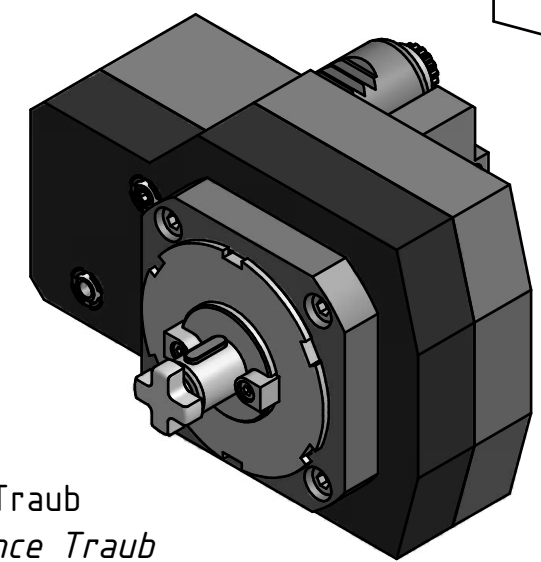

Hakenschlüssel  
mit Nase  
Hook wrench with  
nose end  
DIN1810 A 68x75

Copyright **EWS Tool Technologies**  
Weitergabe und Vervielfältigung dieser Unterlage,  
Verwertung und Mitteilung ihres Inhalts nicht  
gestattet, soweit nicht ausdrücklich zugestanden.  
Zu widerhandlungen verpflichten zu Schadenersatz.

Bemerkung - Note mit Kegelrollenlager with taper roller bearing(s)	Technische Daten - technical data $M1 / M2 = 20 / 60 \text{ Nm}$ $n1 / n2 = 6000 / 2000 \text{ 1/min}$ $i (N1:N2) = 3:1$	Benennung - Title <b>Axial Fräskopf , achsversetzt</b> <b>Axial milling head offset</b>	<table border="1"> <tr> <td>name</td> <td>date</td> </tr> <tr> <td>Schmid</td> <td>06.02.2014</td> </tr> </table>	name	date	Schmid	06.02.2014	Technische Aenderungen vorbehalten! Subject to technical modifications! Nr. <b>52.2516KRL5480RLI3L76</b> MNR: 172460 IDENT: D-EWS-151118 - Blatt - page 1 (1)
name	date							
Schmid	06.02.2014							

