

Spannzange / collet ER25 DIN6499  
Spannbereich / clamping range: 1,0 - 16,0

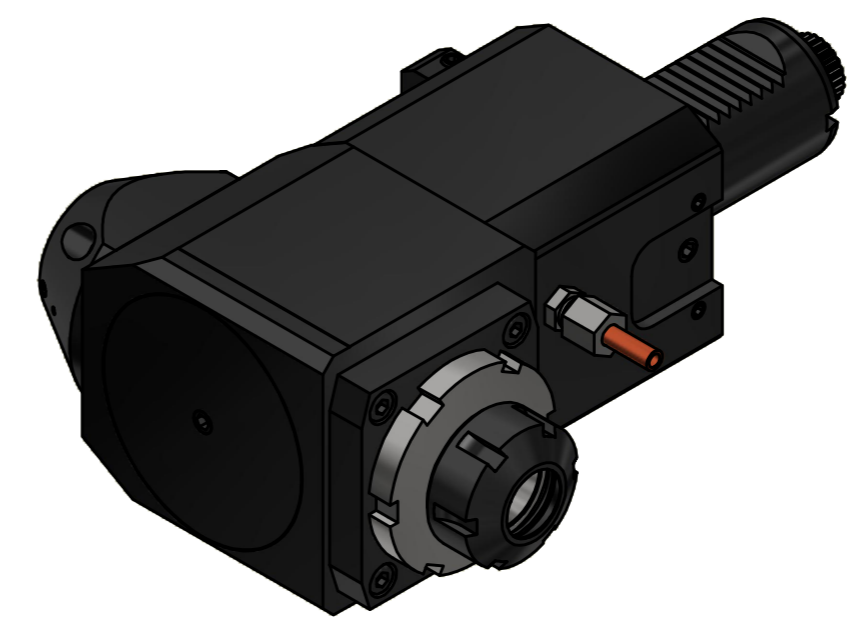

Hakenschlüssel mit Nase  
Hook wrench with nose end  
DIN1810 A 58x62

Spannzangenschlüssel  
Clamping wrench  
225

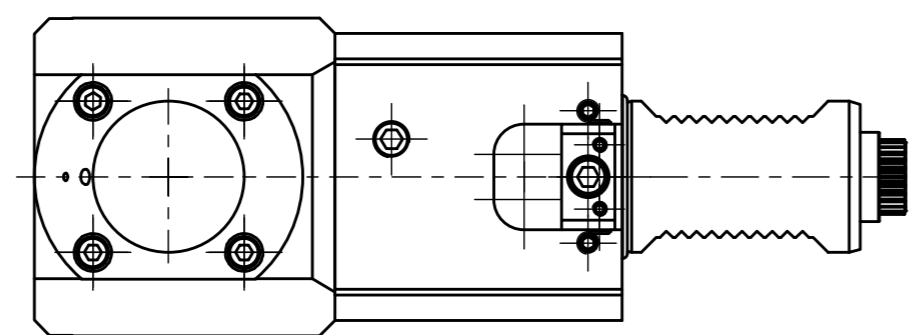

Doppelverzahnung Lizenz Traub  
double tooth system licence Traub

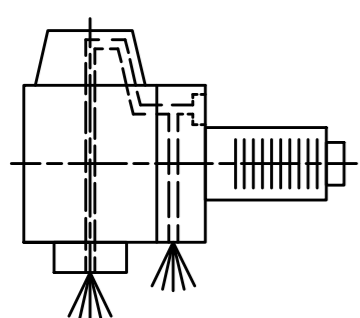

Innen- und Aussenkuehlung / Inside and outside coolant supply  
Kein Trockenlauf / No dry run  
Kuehlmittelfiltrierung=50µ / coolant filtration=50µ

Copyright EWS Tool Technologies  
Weitergabe und Vervielfaeltigung dieser Unterlage, Verwertung und Mitteilung ihres Inhalts nicht gestattet, soweit nicht ausdrecklich zugestanden. Zuwiderhandlungen verpflichten zu Schadenersatz.

<p>Bemerkung - Note Nicht ohne Kuehlmittel betreiben! Not for use without coolant-fluid!</p>	<p>Technische Daten - technical data Weight = 7.768 [kg] Torque max. (M1/M2) = 45 / 15 [Nm] Speed max. (n1/n2) = 5000 / 15000 [1/min] Gear ratio (i)=n1:n2 = 1:3 Pressure (pmax) = 70 [bar]</p>	<p>Benennung - Title <b>Radial Bohr und Fräskopf</b> <b>Radial drilling and milling head</b></p>	<p><b>EWS</b> Tool Technologies EWS Weigle GmbH &amp; Co. KG Maybachstr. 1 D-73066 Uhlingen www.ews-tool.de</p>	<p>Technische Aenderungen vorbehalten! Subject to technical modifications! IDENT: DEWS250778</p>	<p>REV: -/A MNR. 159461</p>
--	---	--	---	--	-------------------------------------

