

W-Verzahnung Lizenz Index-Werke
W-tooth system licence Index-Corporation

Spannzange / *Collet* ER16 DIN6499
 Spannbereich / *Clamping range*: 1,0 - 10,0

Gewindebohrzange / *Tapping Collet*
 ET-1-16 M1-M6

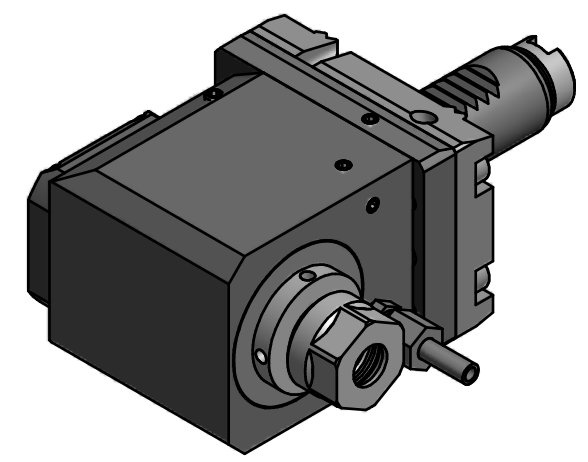
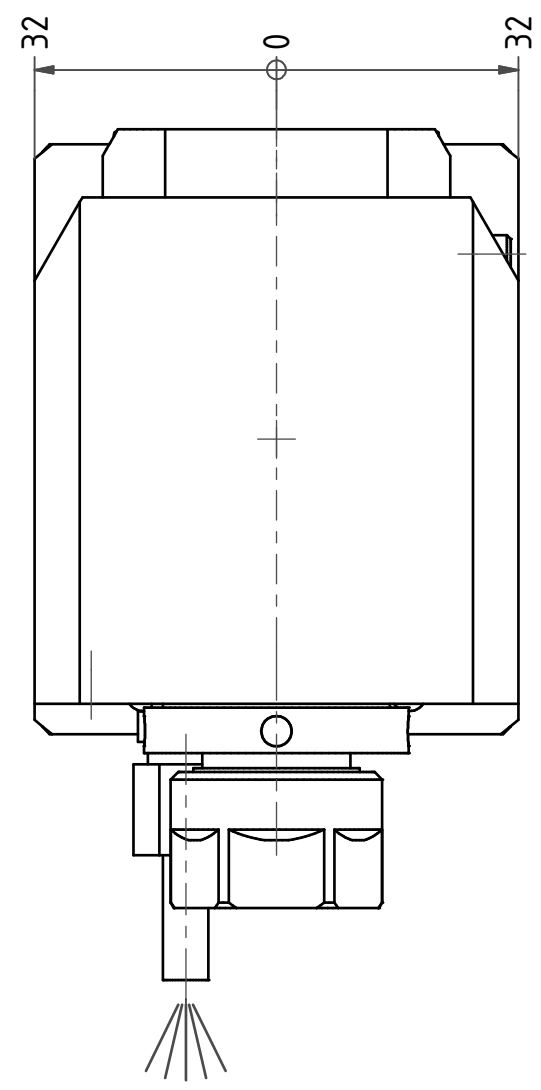

Hakenschlüssel
 mit Zapfen
*Hook wrench
 with fixed pin*
 DIN1810 B 34x36

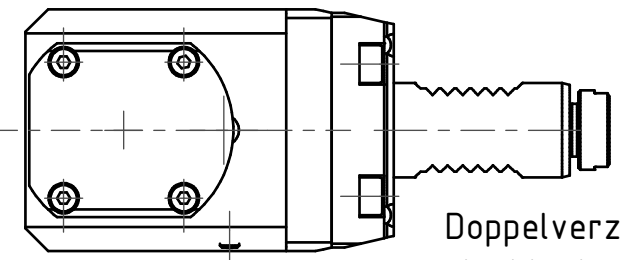

Doppelverzahnung Lizenz Traub
double tooth system licence Traub

Copyright **EWS Tool Technologies**
 Weitergabe und Vervielfaeltigung dieser Unterlage,
 Verwertung und Mitteilung ihres Inhalts nicht
 gestattet, soweit nicht ausdrecklich zugestanden.
 Zuwiderhandlungen verpflichten zu Schadenersatz.

| | | | | | | |
|-------------------------|---|--|---|--------|---|--|
| Bemerkung - <i>Note</i> | Technische Daten - <i>technical data</i> $M_1 / M_2 = 24 / 12 \text{ Nm}$ $n_1 / n_2 = 6000 / 12000 \text{ 1/min}$ $i (N_1:N_2) = 1:2$ | Benennung - <i>Title</i> Radial Bohr und Fräskopf <i>Radial drilling and milling head</i> | name | date | Technische Aenderungen vorbehalten! <i>Subject to technical modifications!</i> |  Nr. 60.2516G200RL1W DIN A3 |
| | | | drawing | Theiss | | |
| | | |  Weigele GmbH & Co. KG Maybachstr. 1 D-73066 UHINGEN Tel. +49(0)7161/93040-10 | | File: D-EWS-1594.10-.idw Blatt - page 1 (1) | |