

Spannzange / collet ER32 DIN6499
 Spannbereich / clamping range: 2,0 - 20,0

Gewindebohrzange / tapping collet
 ET-1-32 M5-M12



Hakenschlüssel
 mit Nase
 Hook wrench with
 nose end
 DIN1810 A 68x75

Spannzangenschlüssel für
 innenliegende Mutter
 Clamping wrench for
 internal collet
 232AX

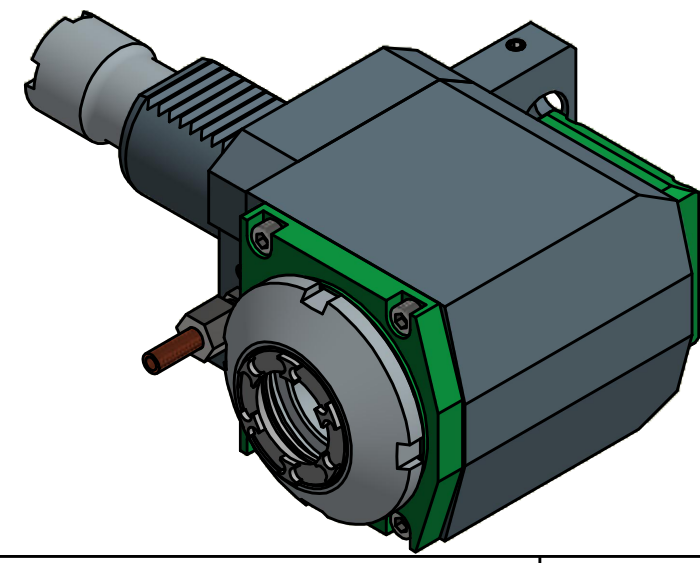

Copyright **EWS Tool Technologies**
 Weitergabe und Vervielfältigung dieser Unterlage,
 Verwertung und Mitteilung ihres Inhalts nicht
 gestattet, soweit nicht ausdrücklich zugestanden.
 Zuwiderhandlungen verpflichten zu Schadenersatz.

Bemerkung - Note	Technische Daten - technical data Weight = 5.538 [kg] Torque max. (M1/M2) = 50 / 50 [Nm] Speed max. (n1/n2) = 6000 / 6000 [1/min] Gear ratio (i)=n1:n2 = 1:1	Benennung - Title Radial Bohr und Fräskopf Radial drilling and milling head	 EWS Weigle GmbH & Co. KG Maybachstr. 1 D-73066 UHINGEN www.ews-tools.de Nr. - No. 60.4032LB15LIM	Technische Änderungen vorbehalten! Subject to technical modifications! IDENT: D-EWS-165060 MNR. 145366	 
------------------	--	---	--	---	--