

Spannzange / collet ER25 DIN6499
 Spannbereich / clamping range: 1,0 - 16,0

Gewindebohrzange / tapping collet
 ET-1-25 M3-M12

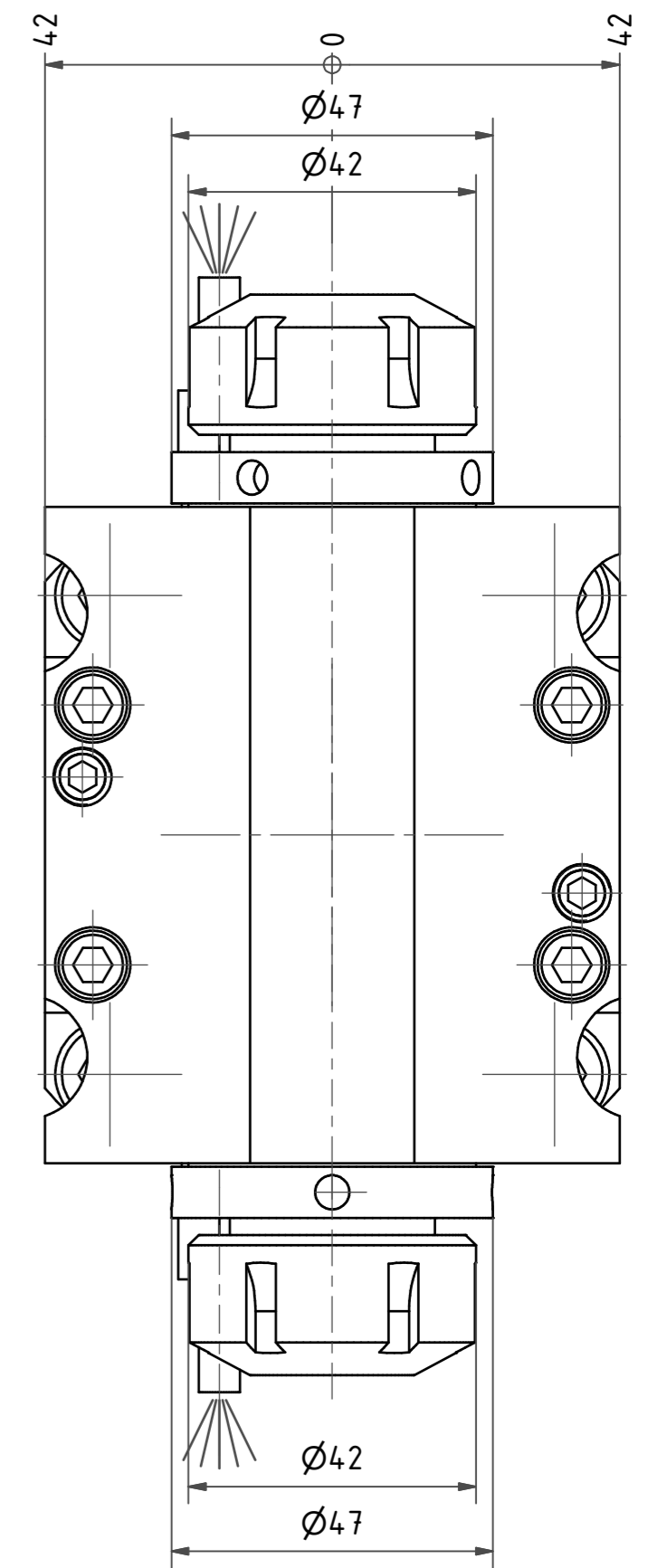
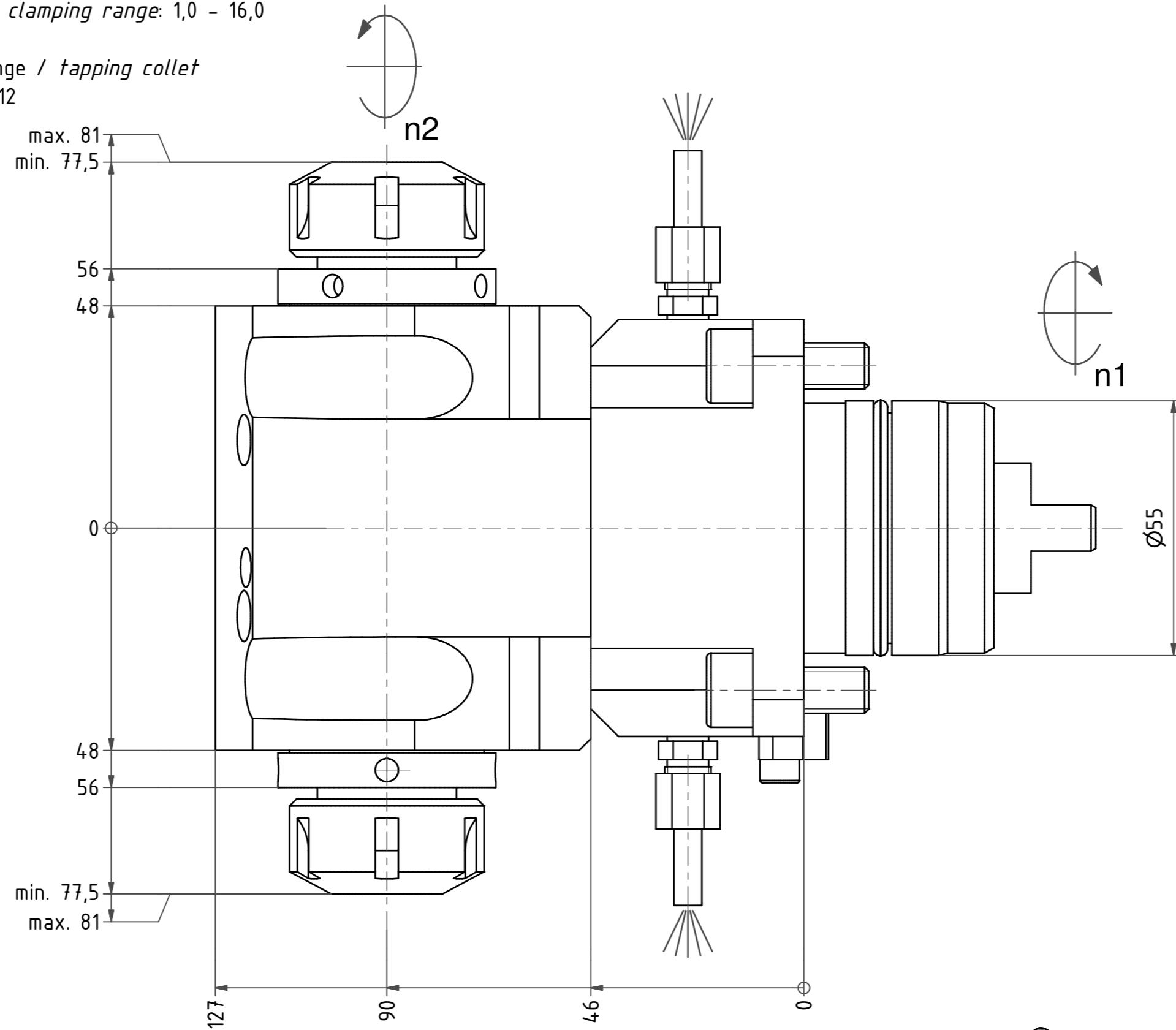
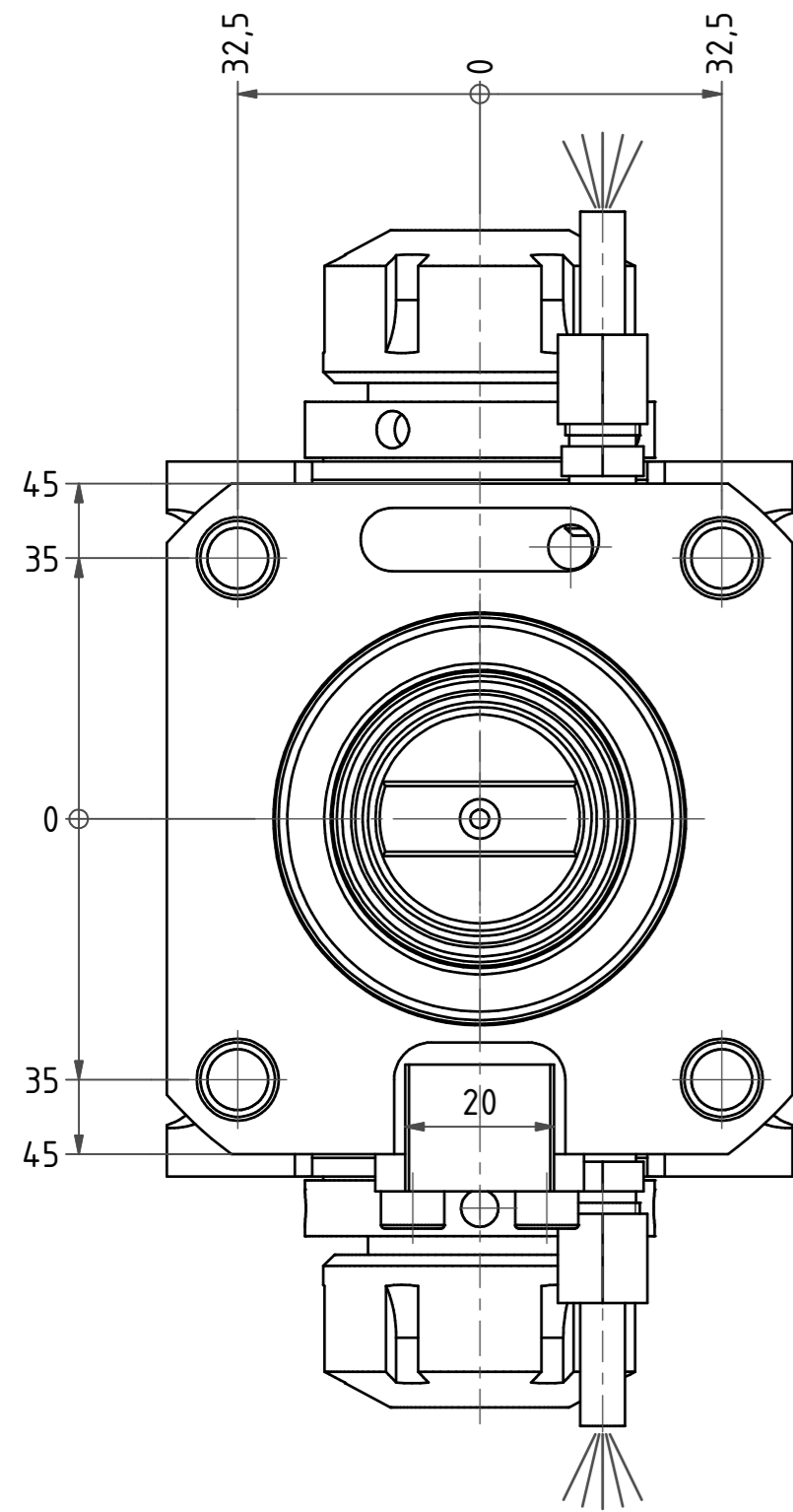

Spannzange / collet ER25 DIN6499
 Spannbereich / clamping range: 1,0 - 16,0

Gewindebohrzange / tapping collet
 ET-1-25 M3-M12

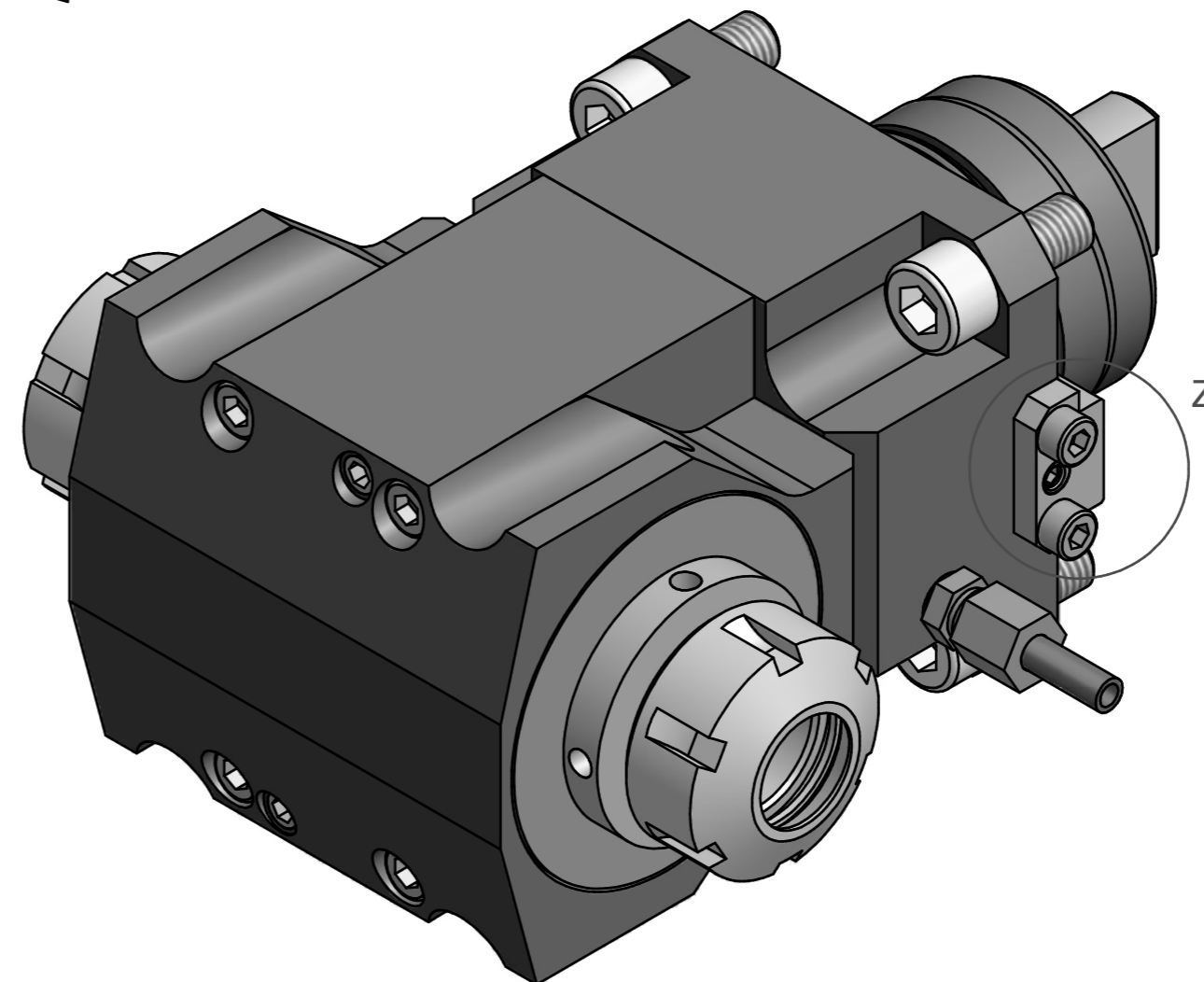
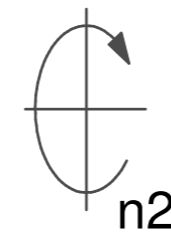

Z (2:1)

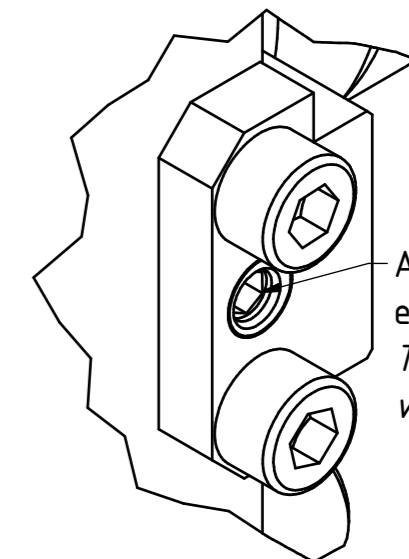

Ausrichtklotz ist über ein Exzenter einstellbar.
 The block is adjustable via eccentric.

Hakenschlüssel mit Zapfen
 Hook wrench with fixed pin
 DIN1810 B 45x50

Spannzangenschlüssel
 Clamping wrench
 225

Bemerkung - Note	Technische Daten - technical data Weight = 7,031 [kg] Torque max. (M1/M2) = 50 / 50 each Sp. [Nm] Speed max. (n1/n2) = 6000 / 6000 [1/min] Gear ratio (i)=n1:n2 = 1:1	Benennung - Title Radial Bohr und Fräskopf <i>Radial drilling and milling head</i>	 EWS Weigle GmbH & Co. KG Maybachstr. 1 D-73066 Ulm/lingen www.ews-tools.de	Technische Änderungen vorbehalten! Subject to technical modifications! IDENT: 0-EWS-120128 Nr. - No. 60.5525DNE X906X90	REV: -/- MNR. 159351	
------------------	---	---	---	--	-------------------------	--

Copyright **EWS Tool Technologies**
 Weitergabe und Vervielfältigung dieser Unterlage,
 Verwertung und Mitteilung ihres Inhalts nicht
 gestattet, soweit nicht ausdrücklich zugestanden.
 Zuwiderhandlungen verpflichten zu Schadenersatz.