

Z (2:1)

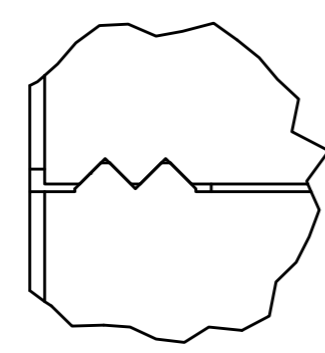

Gewindebohrungen für Winkelausrichtung  
Thread holes for angle adjusting.

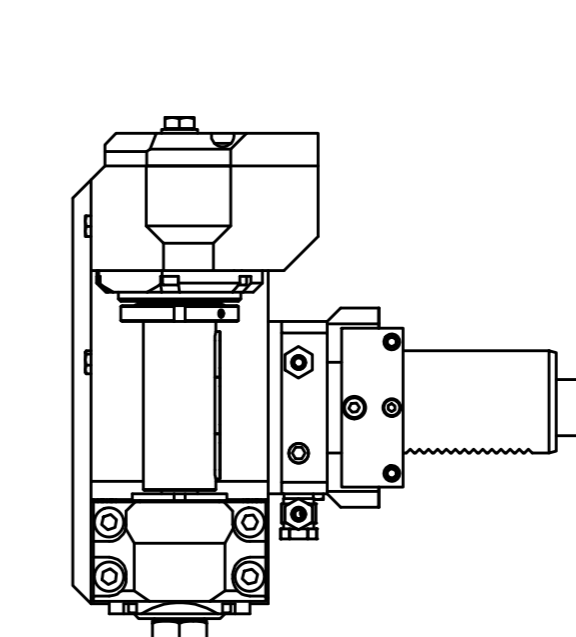
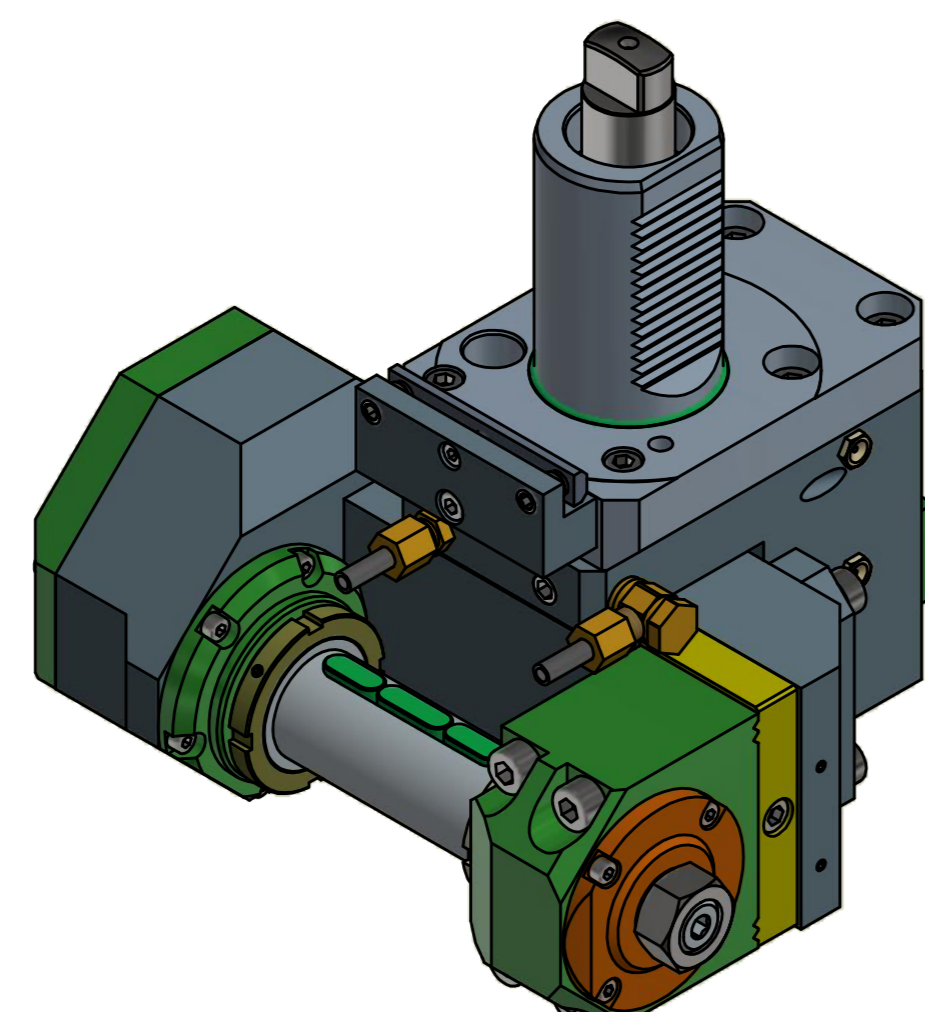
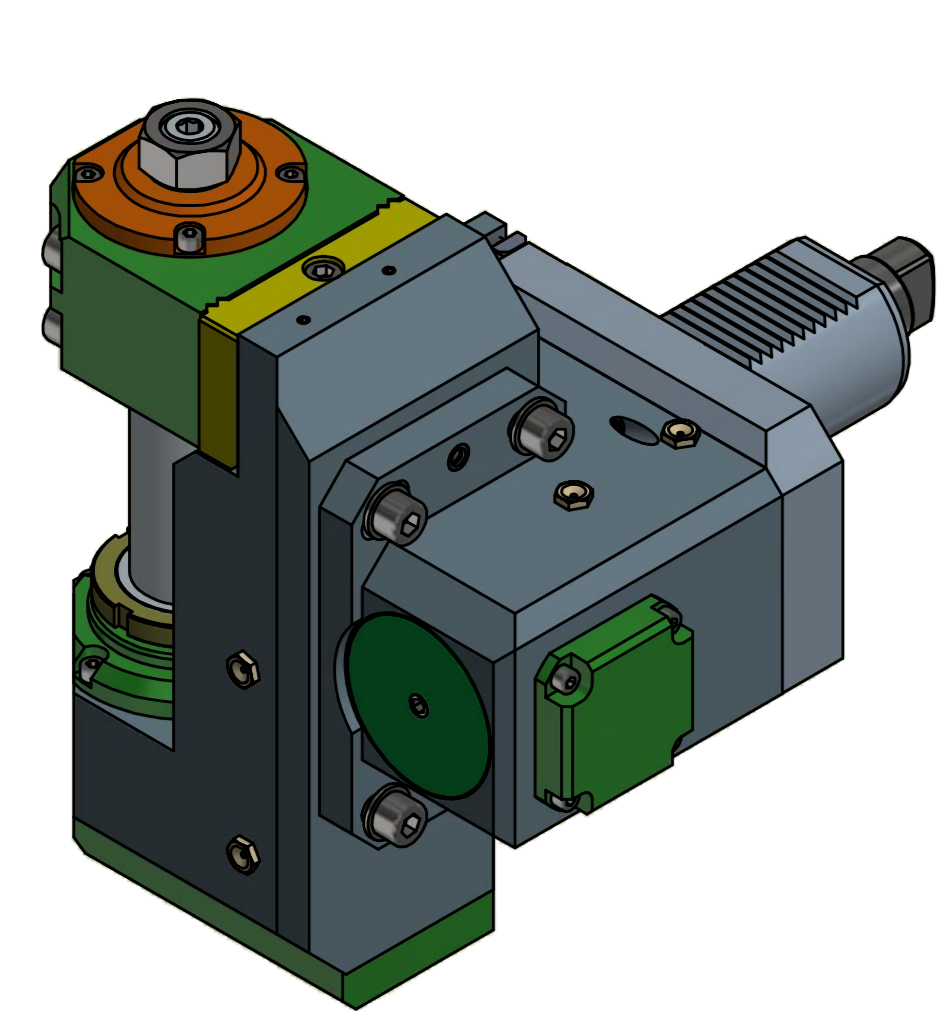
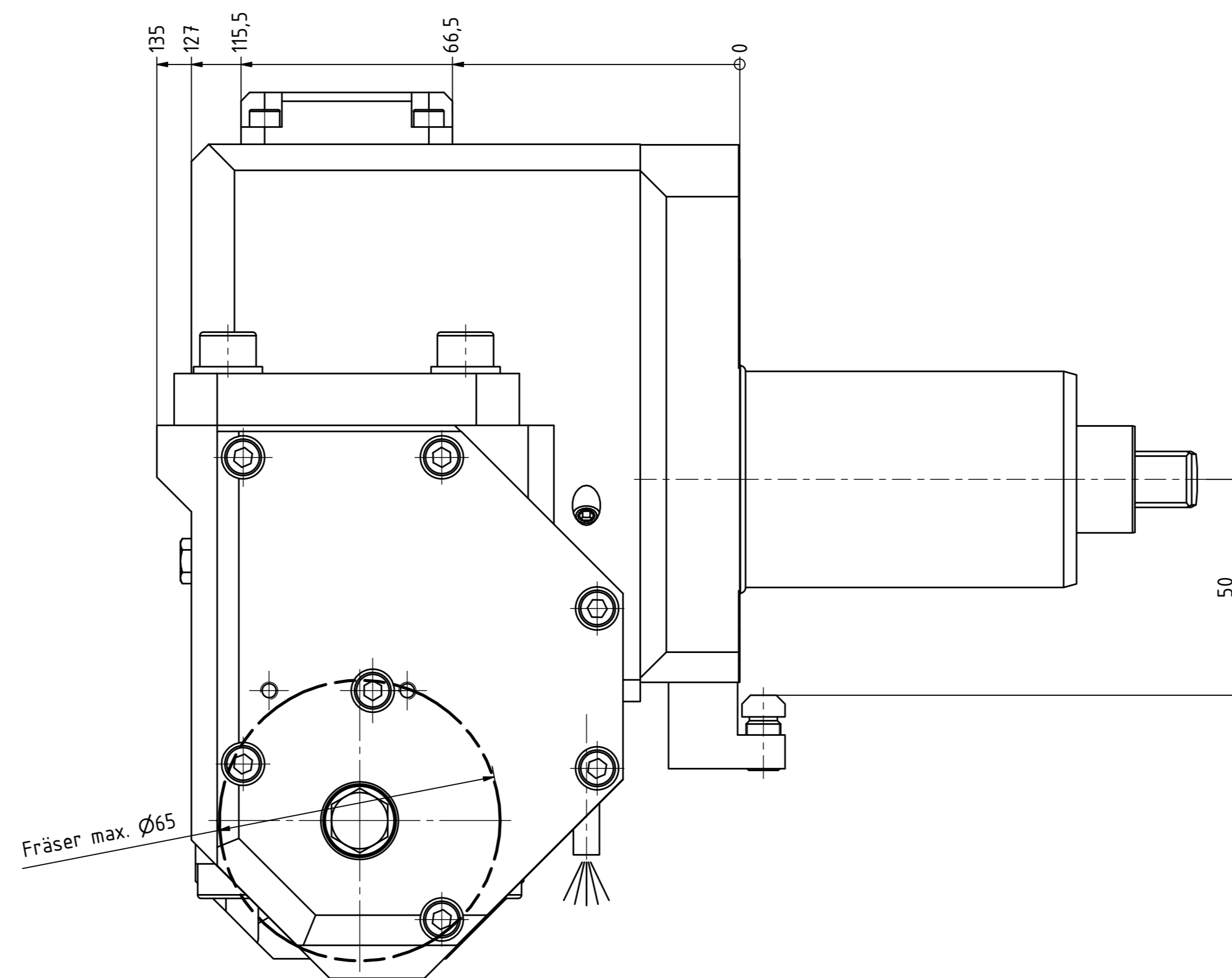
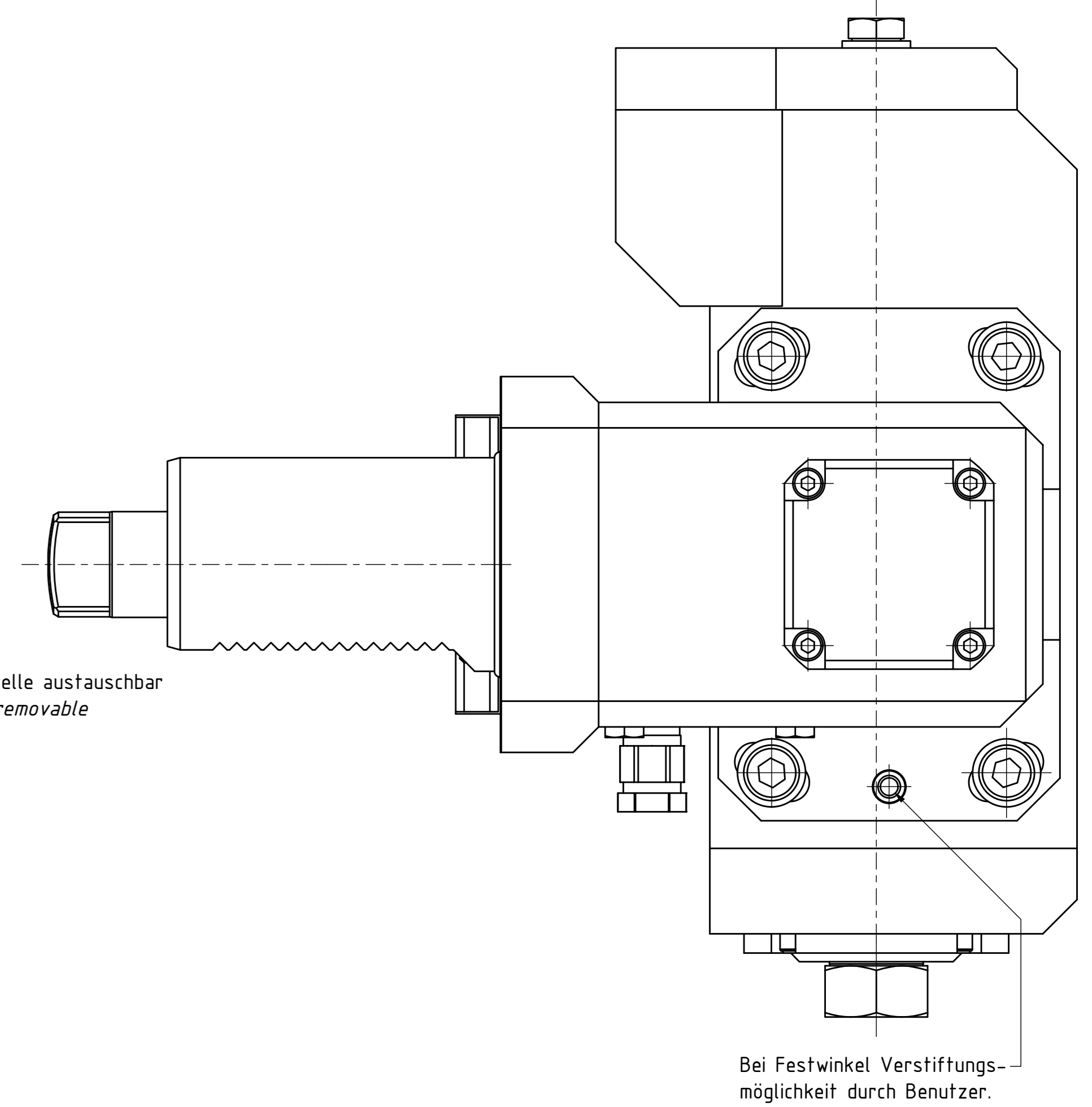
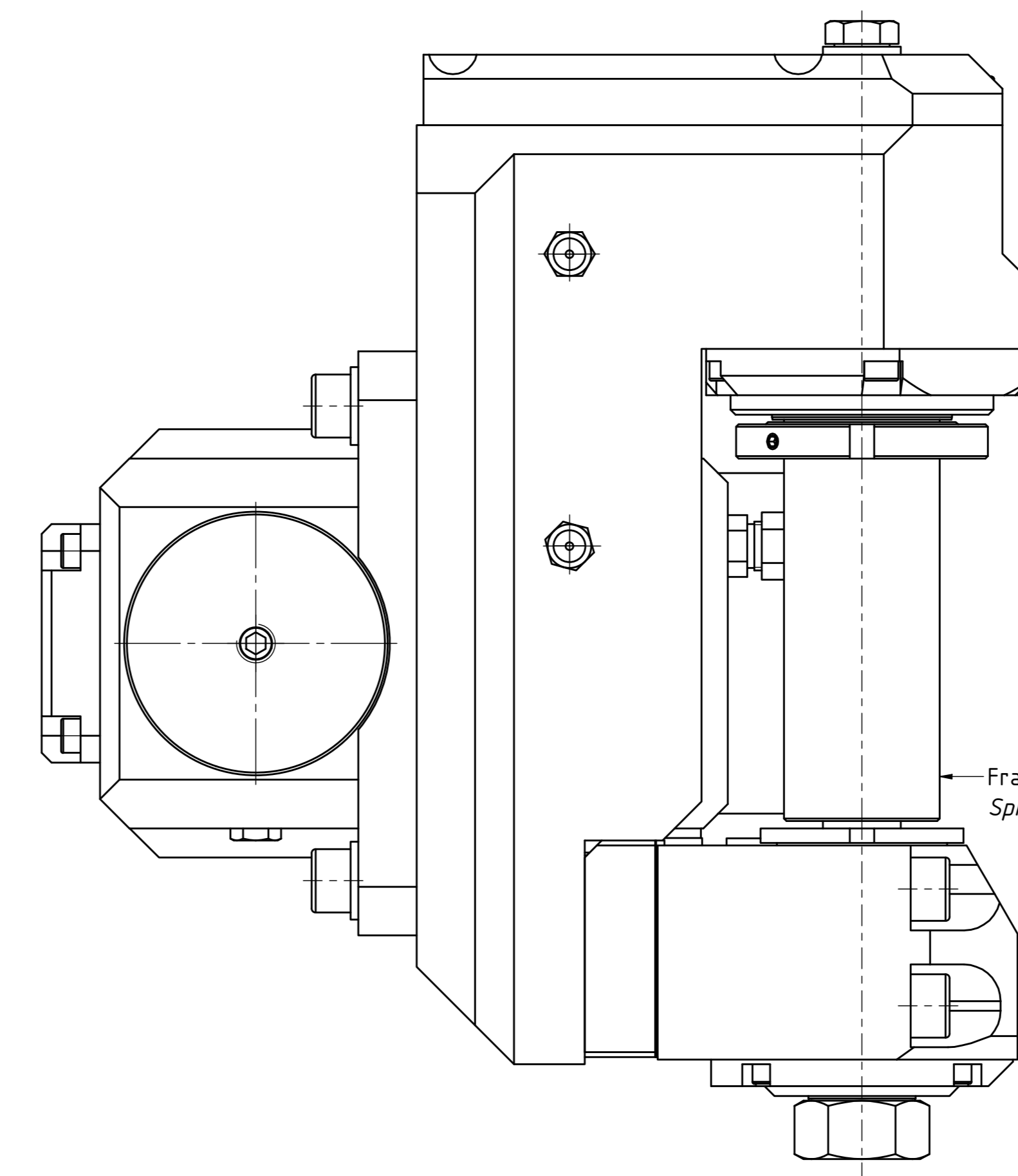
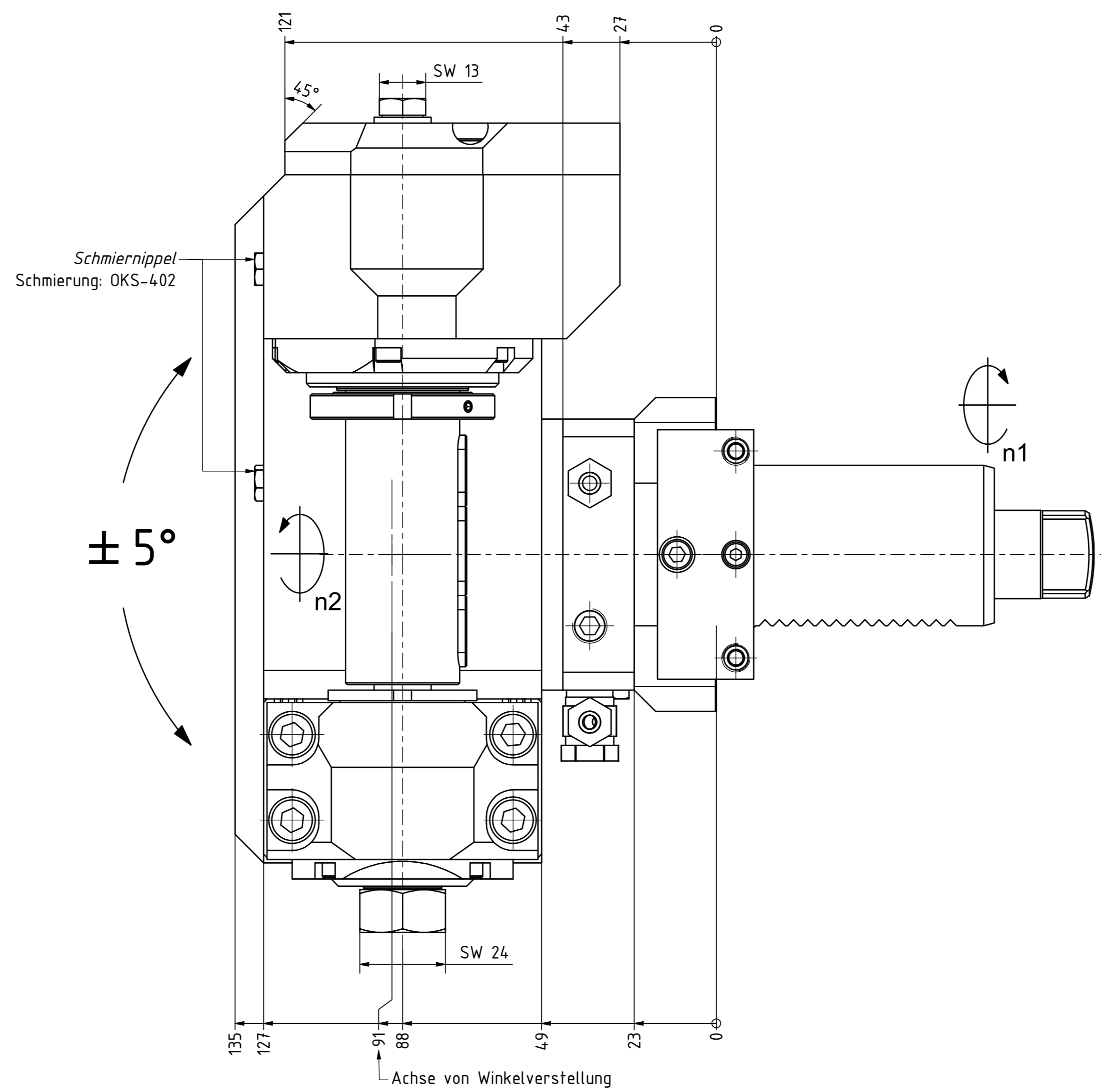
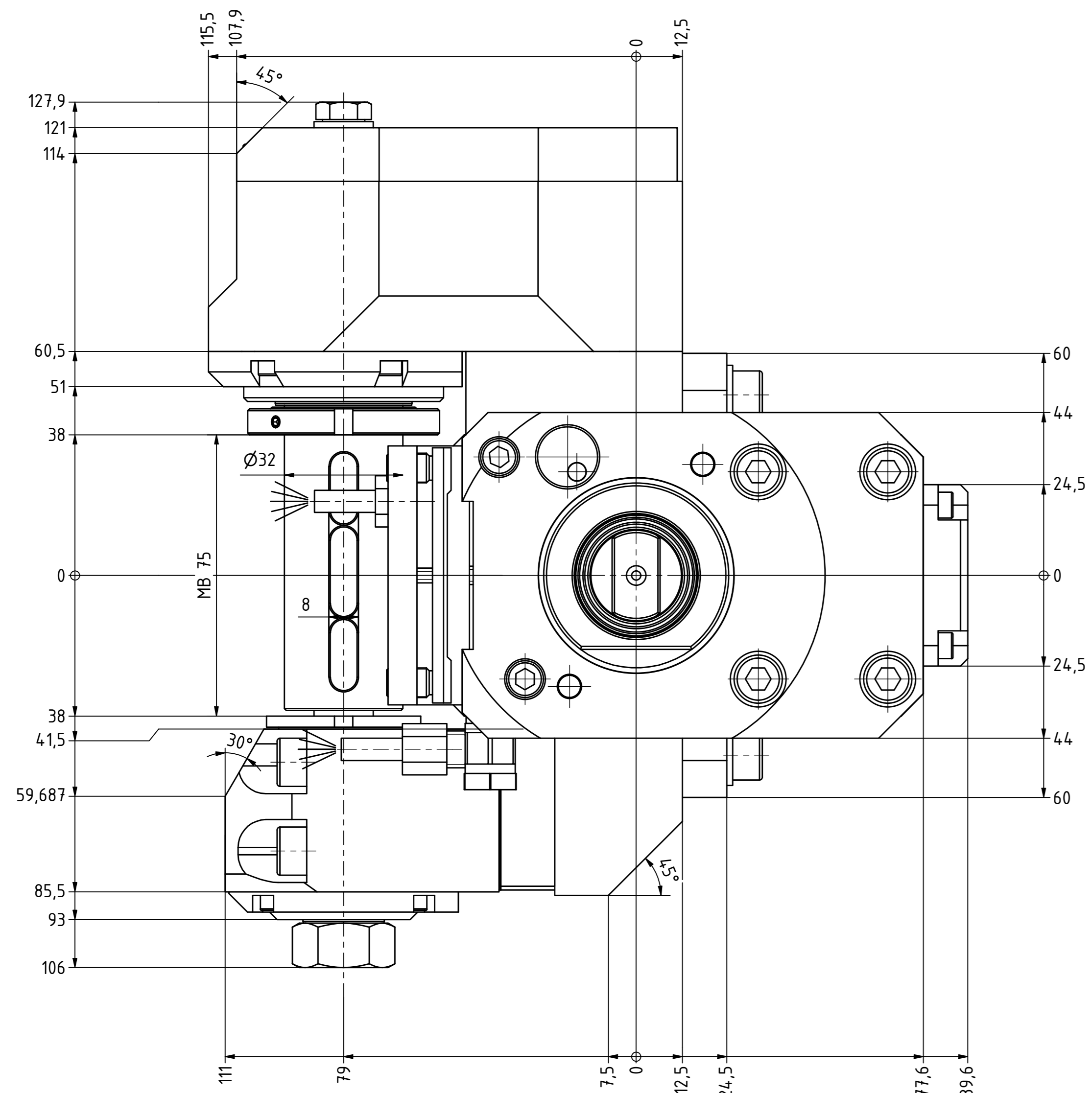
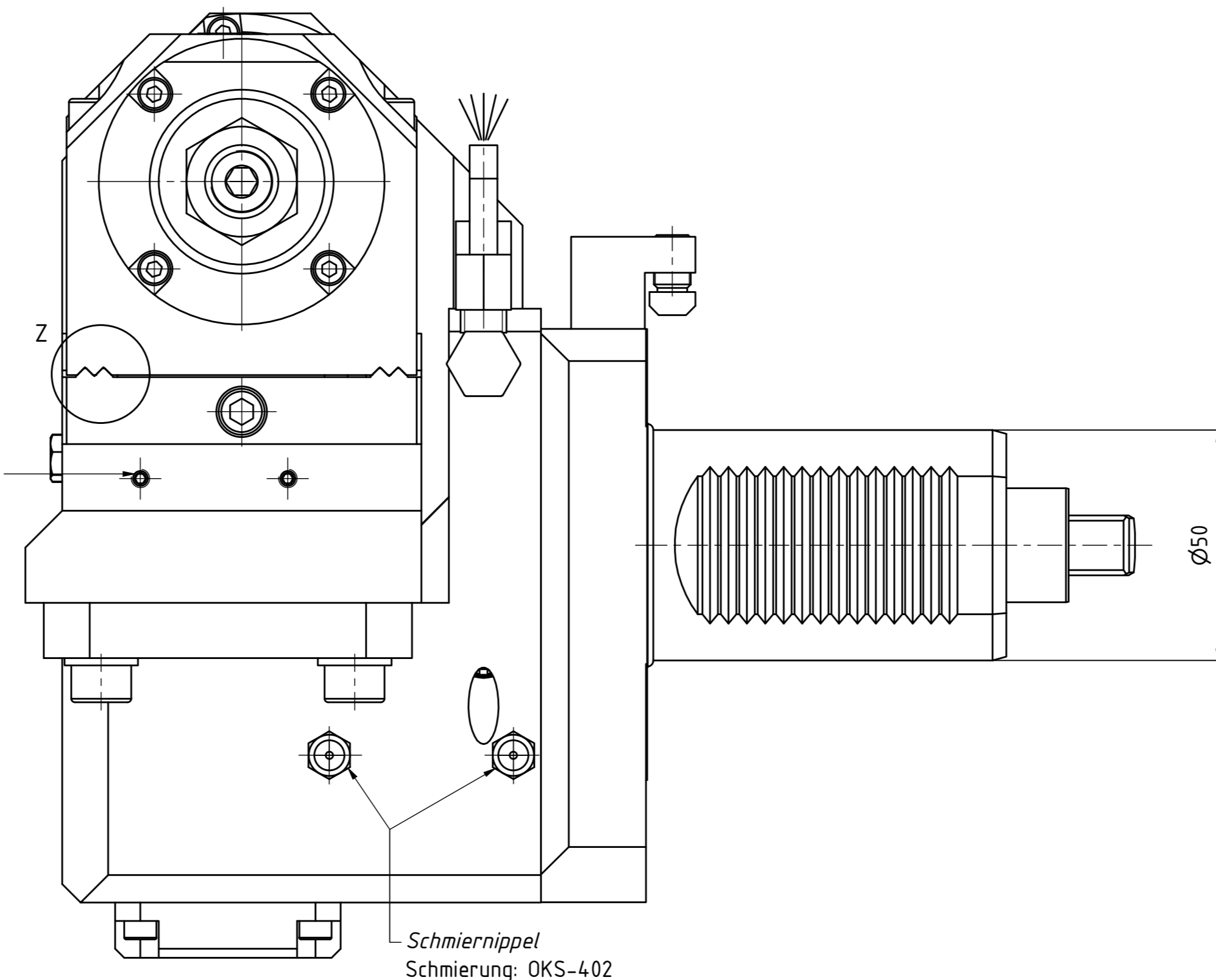

Doppelverzahnung Lizenz Traub  
double tooth system licence Traub

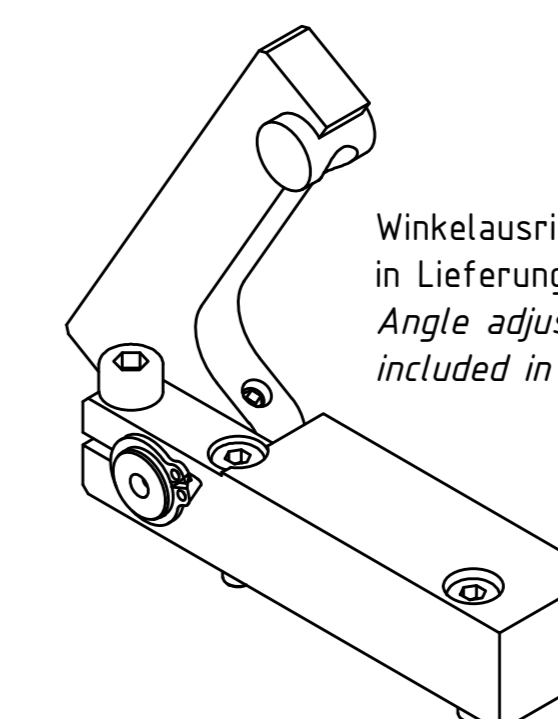

Winkelausrichtung & CD-ROM  
in Lieferung enthalten!  
Angle adjusting & CD-ROM  
included in delivery!

Beide Nachbarstationen nicht verwendbar!  
Both neighbour stations are not useable!

mit Kegelrollenlagern  
with taper roller bearings

Technische Daten - Technical data  
Weight = 15,189 [kg]  
Torque max (n1/n2) = 50 / 50 [Nm]  
Speed max (n1/n2) = 6000 / 6000 [1/min]  
Gear ratio (i)=n1/n2 = 1:1

Radial Scheibenfräserkopf versetzt  
Saw milling spindle offset

EWS  
84.50321809HESSLTKWZ79MB75  
159278

Copyright EWS Tool Technologies  
Weitergabe und Vervielfältigung dieser Unterlagen,  
Vervielfältigung und Mithaltung ohne schriftliche  
Genehmigung, sowie nicht ausschließlich zugestanden.  
Zusammenfassungen verpflichtet zu Schadenersatz.

TECHNISCHE ANDERUNGEN VERBODEN!  
Subject to technical modifications!  
84.50321809HESSLTKWZ79MB75  
159278  
QR