

Doppelverzahnung Lizenz Traub
double tooth system licence Traub

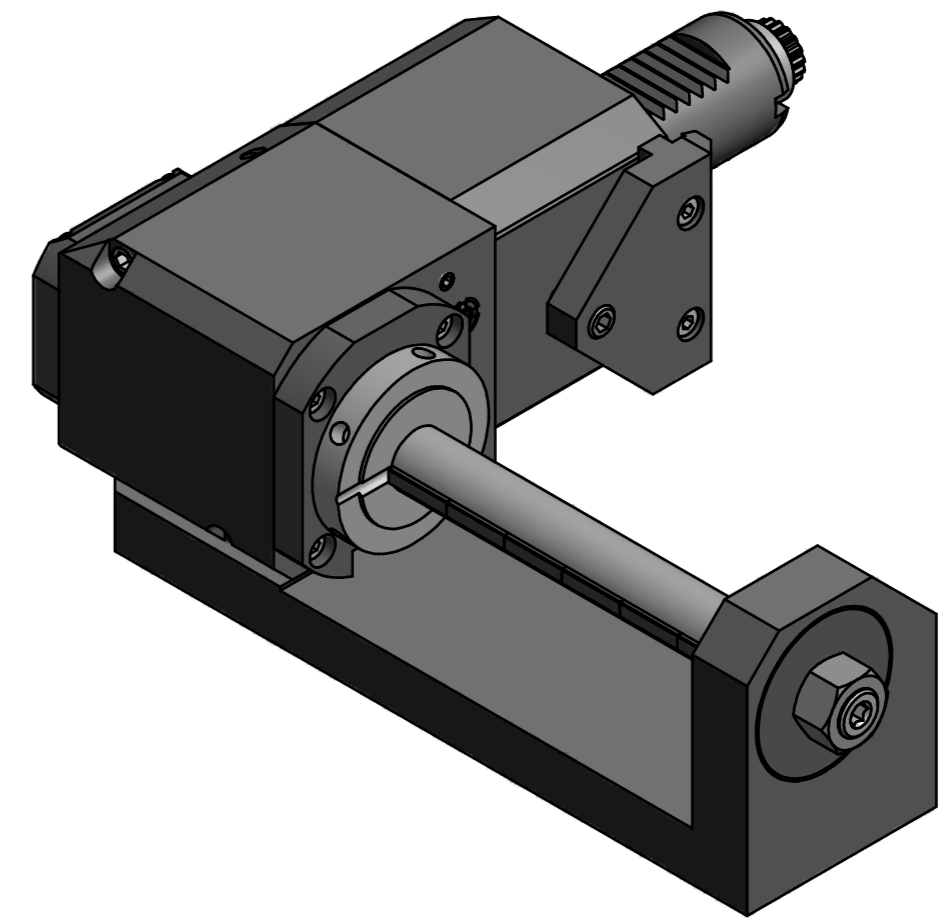

Hakenschlüssel
mit Zapfen
Hook wrench
with fixed pin
DIN1810 B 45x50

Copyright **EWS Tool Technologies**
Weitergabe und Vervielfältigung dieser Unterlage,
Verwertung und Mitteilung ihres Inhalts nicht
gestattet, soweit nicht ausdrücklich zugestanden.
Zu widerhandlungen verpflichtet zu Schadenersatz.

Bemerkung - Note mit Kegelrollenlager with taper roller bearing(s)	Technische Daten - technical data $M_1 / M_2 = 25 / 25 \text{ Nm}$ $n_1 / n_2 = 6000 / 6000 \text{ 1/min}$ $i (N_1:N_2) = 1:1$	Benennung - Title Radial Fräskopf <i>Radial milling head</i>	name date 23.11.2012	Technische Änderungen vorbehalten! Subject to technical modifications!
			drawing Sigel EWS EWS Weigte GmbH & Co. KG Maybachstr. 1 D-72096 Ulm/lingen Tel. +49(0)7161/93040-100 Tool Technologies	
			IDENT: D-EWS-128806 A	Blatt - page 1 (1)