

Innen- und Aussenkuehlung / Inside and outside coolant supply  
 Kein Trockenlauf / No dry run  
 Kuehmittelfiltrierung-50µ / coolant filtration-50µ

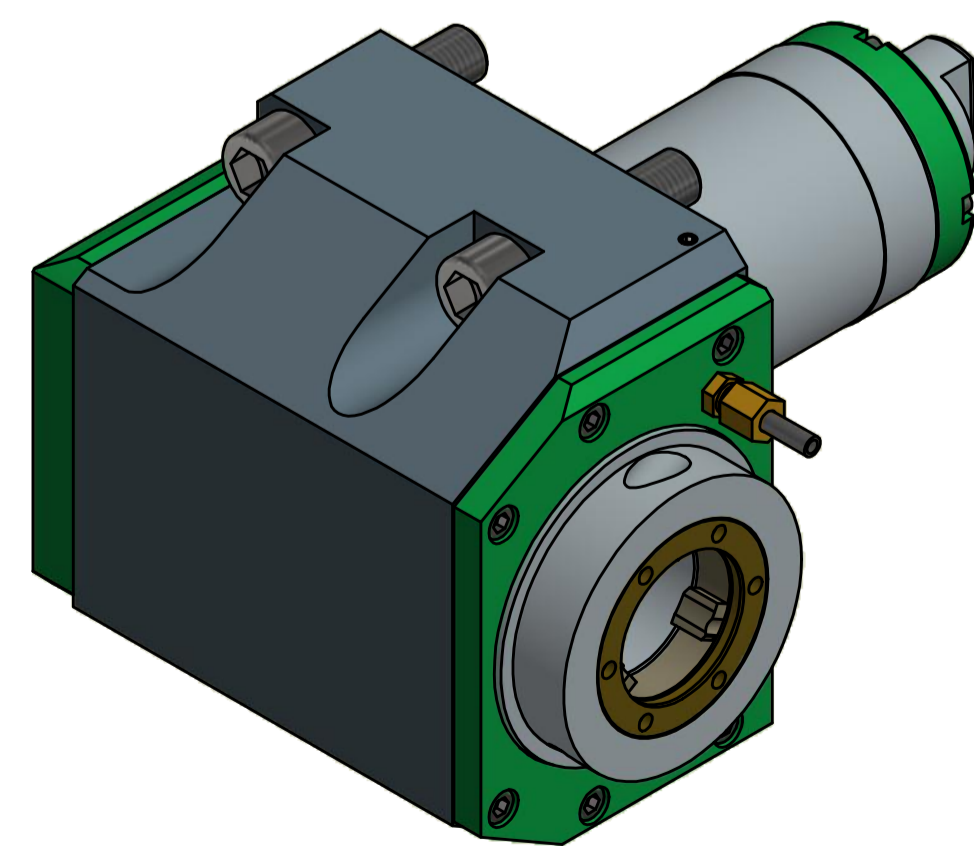

Schutzrecht angemeldet  
 Trademark right applied

Bemerkung - Note  
 Nicht ohne Kuehmittel betreiben!  
 Not for use without coolant-fluid!

Technische Daten - technical data  
 Weight = 21,486 [kg]  
 Torque max. (M1/M2) = 80 / 160 [Nm]  
 Speed max. (n1/n2) = 4000 / 2000 [1/min]  
 Gear ratio (i)=n1:n2 = 2:1  
 Pressure (pmax) = 70 [bar]

Bemerkung - Note  
 Radial Bohr und Fräskopf  
 Radial drilling and milling head

EWS Werkzeug-Genuss & Co. KG  
 Hauptstr. 1  
 62700 Limburg  
 www.ews-tool.de  
 Technische Änderungen vorbehalten!  
 Subject to technical modifications!  
 IDENT: DEWS049078  
 Nr. - No.  
 60.108V5KRHOWAIK12

REV. -/A  
 HNR.  
 152468



Copyright EWS Tool Technologies  
 Weitergabe und Vervielfaeligung dieser Unterlage,  
 Verwertung und Mitteilung ihres Inhalts nicht  
 gestattet, soweit nicht ausdrecklich zugestanden.  
 Zuwiderhandlungen verpflichten zu Schadenersatz.