

Spannzange / collet ER32 DIN6499
Spannbereich / clamping range: 2,0 - 20,0

Gewindebohrzange / tapping collet
ET-1-32 M5-M12

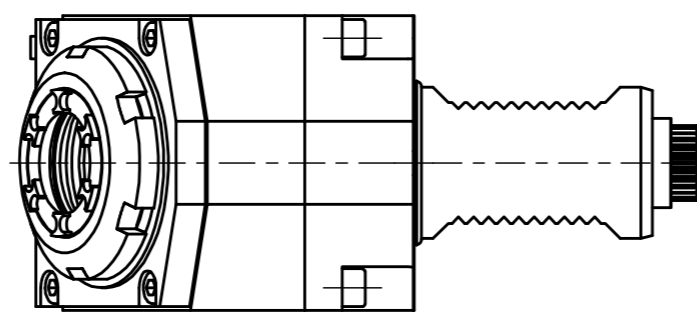
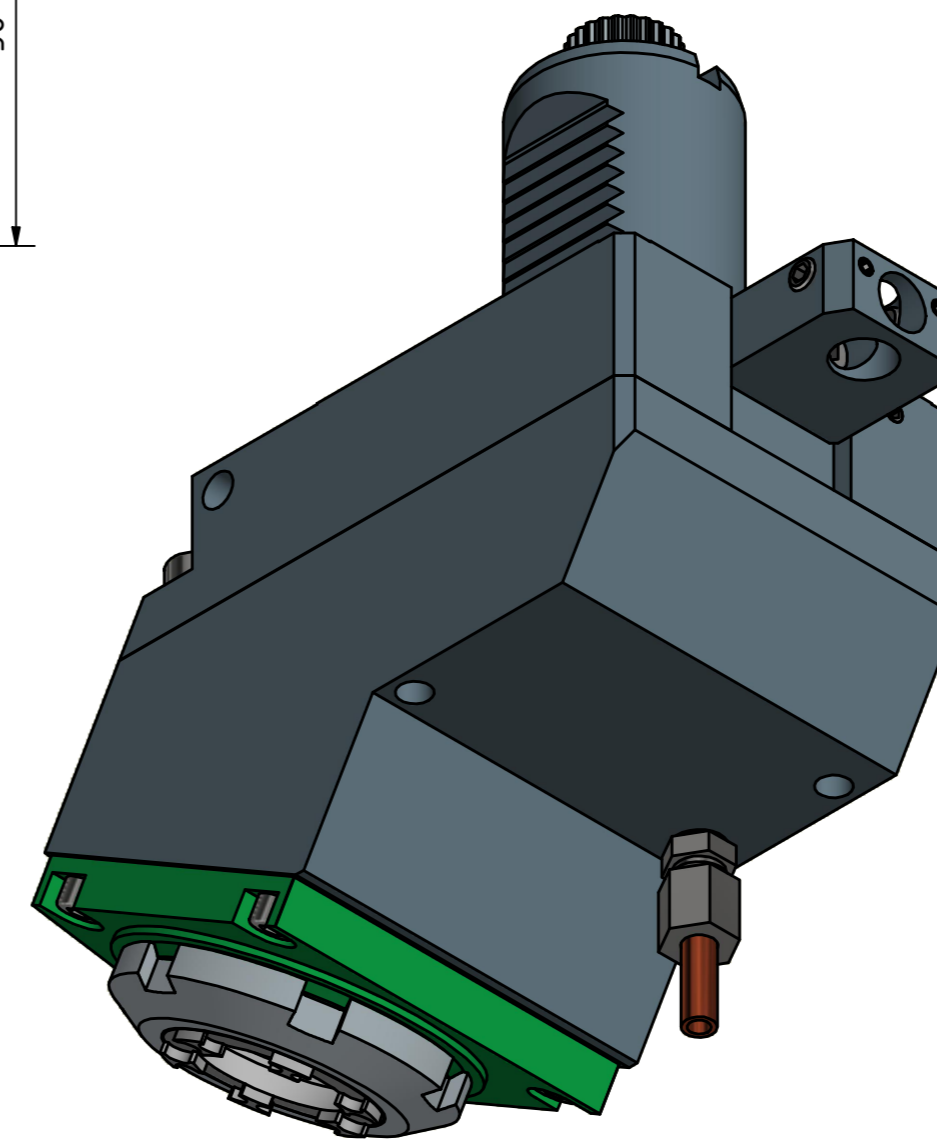
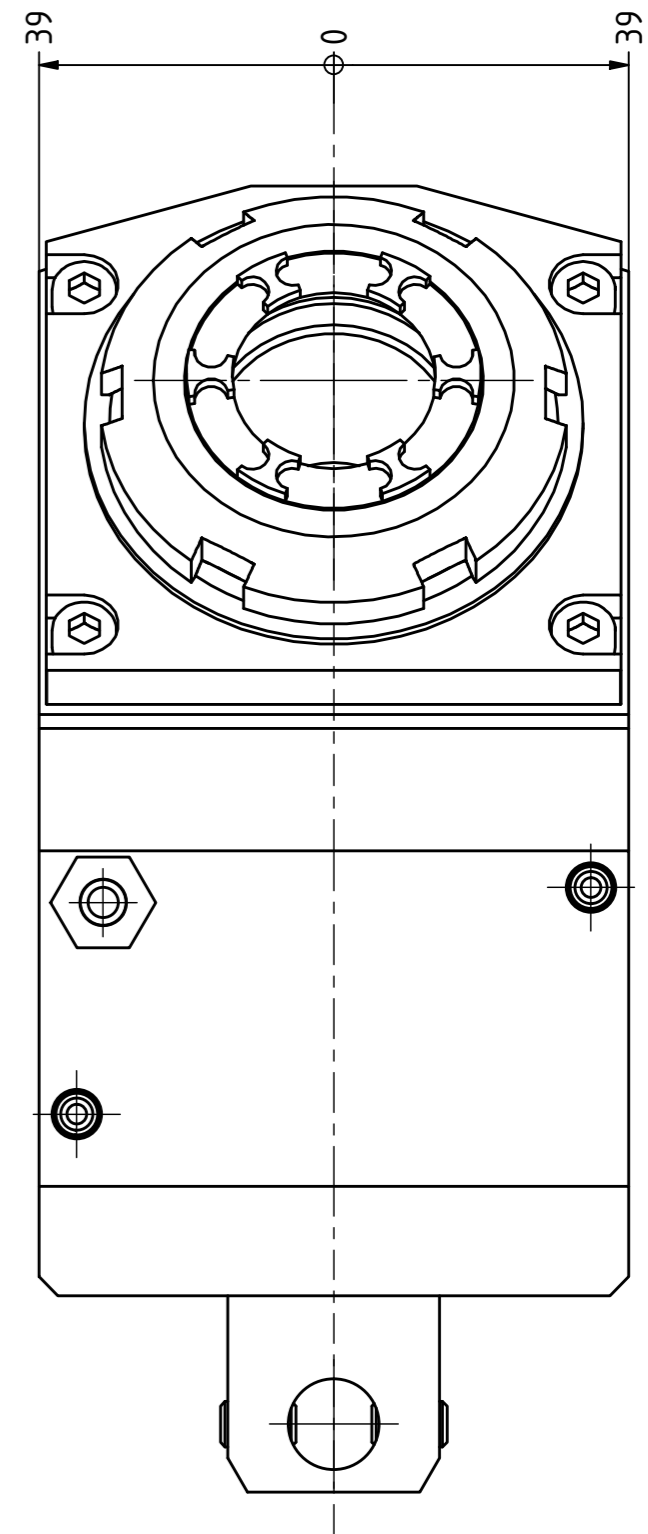
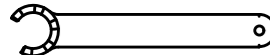

Doppelverzahnung Lizenz Traub
double tooth system licence Traub

Spannzangenschlüssel für
innenliegende Mutter
Clamping wrench for
internal collet
232AX

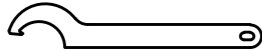
Hakenschlüssel
mit Nase
Hook wrench with
nose end
DIN1810 A 58x62

Benennung - Title	Technische Daten - technical data
	Weight = 5.634 [kg]
	Torque max. (M1/M2) = 50 / 50 [Nm]
	Speed max. (n1/n2) = 6000 / 6000 [1/min]
	Gear ratio (i) = n1:n2 = 1:1

Benennung - Title
Radial Bohr und Fräskopf
Radial drilling and milling head

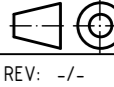
EWS Tool Technologies	EWS Weigle GmbH & Co. KG Maybachstr. 1 D-73066 Ulmringen www.ews-tools.de	Technische Änderungen vorbehalten! Subject to technical modifications!	
Nr. - No.	IDENT: D-EWS-078250	REV: -/-	MNR.
60.4032CTXRLTKW30IM		146624	

Copyright **EWS Tool Technologies**
Weitergabe und Vervielfältigung dieser Unterlage,
Verwertung und Mitteilung ihres Inhalts nicht
gestattet, soweit nicht ausdrücklich zugestanden.
Zu widerhandlungen verpflichten zu Schadenersatz.

