

ABS 50
(Lizenz Komet)

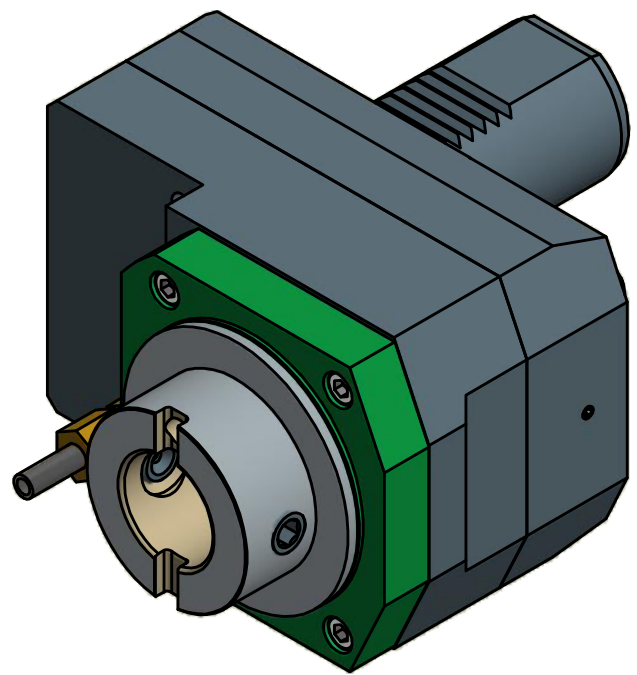

Innen- und Aussenkuehlung / Inside and outside coolant supply
Kuehlmittelfiltrierung+50 μ / coolant filtration+50 μ

Copyright **EWS Tool Technologies**
Weitergabe und Vervielfaeltigung dieser Unterlage,
Verwertung und Mitteilung ihres Inhalts nicht
gestattet, soweit nicht ausdrecklich zugestanden.
Zuwiderhandlungen verpflichten zu Schadenersatz.

<p>Bemerkung - Note</p> <p>Für Trockenlauf geeignet! Use without coolant fluid allowed!</p> <p>mit Kegelrollenlager with taper roller bearing(s)</p>	<p>Technische Daten - technical data</p> <p>Weight = 6.006 [kg]</p> <p>Torque max. (M1/M2) = 40 / 80 [Nm]</p> <p>Speed max. (n1/n2) = 6000 / 3000 [1/min]</p> <p>Gear ratio (i)=n1:n2 = 2:1</p> <p>Pressure (pmax) = 70 [bar]</p>	<p>Benennung - Title</p> <p>Axial Bohr u. Fräskopf achsversetzt Ax. drill. and mill. head offset</p>	<p>EWS Tool Technologies</p> <p>EWS Weigele GmbH & Co. KG Maybachstr. 1 D-73066 UHINGEN www.ews-tools.de</p>	<p>Technische Aenderungen vorbehalten! Subject to technical modifications!</p> <p>IDENT: D-EWS-174534</p>	<p></p> <p>REV: -/-</p> <p>MNR.</p> <p>180911</p>	<p>QR</p>
--	---	--	---	---	---	------------------

Nr. - No.
50.40ABS50KRMP620RIKD12